

VS-Vertikallyft

MONTERINGSANVISNING

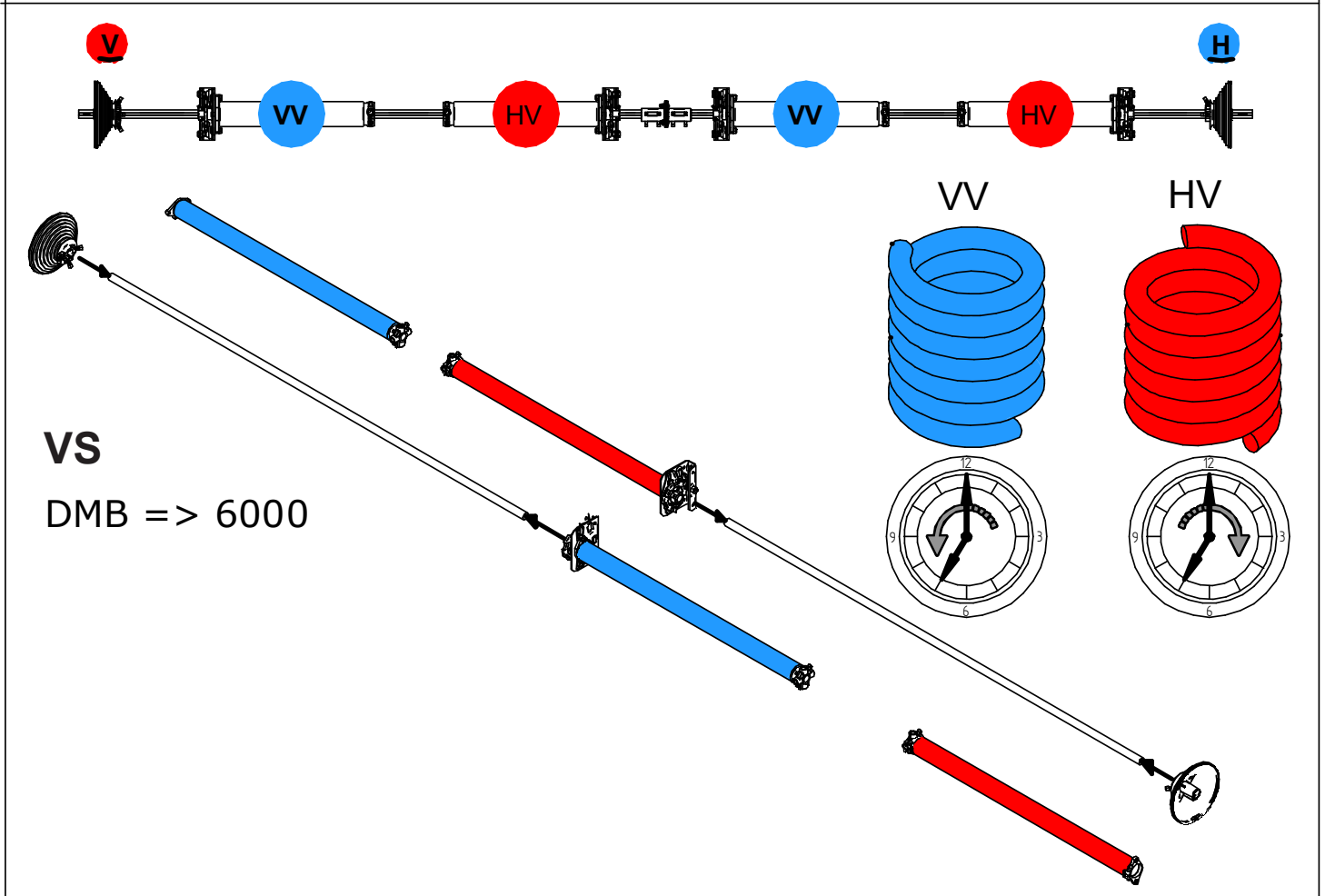

WARNING! VS-fjäderkonfigurationerna på denna sida ersätter **ALLA** övriga VS-fjäderkonfigurationer i denna monteringsanvisning.

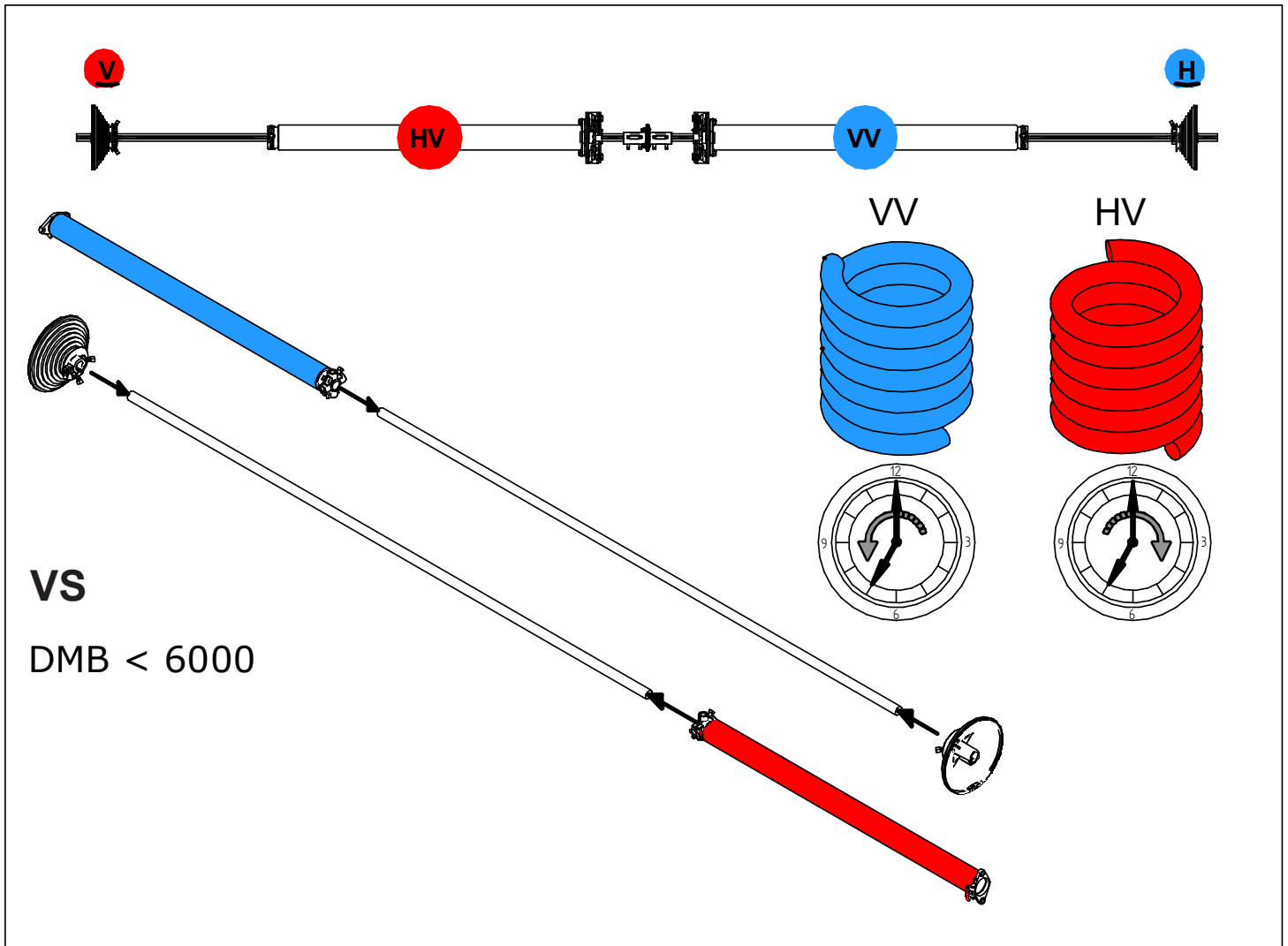

VARNING! VSK-fjäderkonfigurationerna på denna sida ersätter ALLA övriga VSK-fjäderkonfigurationer i denna monteringsanvisning.

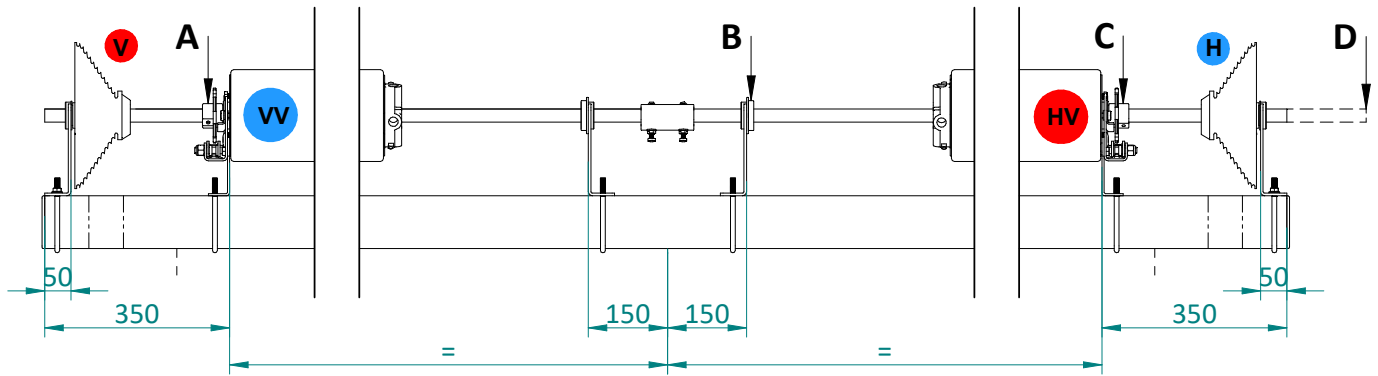

VSK
Standard & Direkt

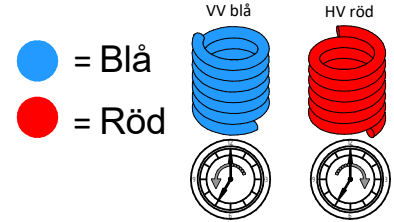
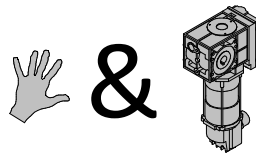

	A	B	C	D
SE	FBS VV eller Lagerstöd + lager	Vid DMB > 4750mm	FBS HV eller Lagerstöd + lager	Motordrift V eller H
EN	SBD LHW or Bearing plate + bearing	When DLW > 4750mm	SBD RHW or Bearing plate + bearing	Motor operated L or R
DE	FBS LHW oder Lagerkonsole + lager	Wenn TLB > 4750mm	FBS RHW oder Lagerkonsole + lager	Antriebe L oder R
FR	Pare-chute ressort LHW ou palier + roulement	LDB > 4750mm	Pare-chute ressort RHW ou palier + roulement	Motorisée D ou G

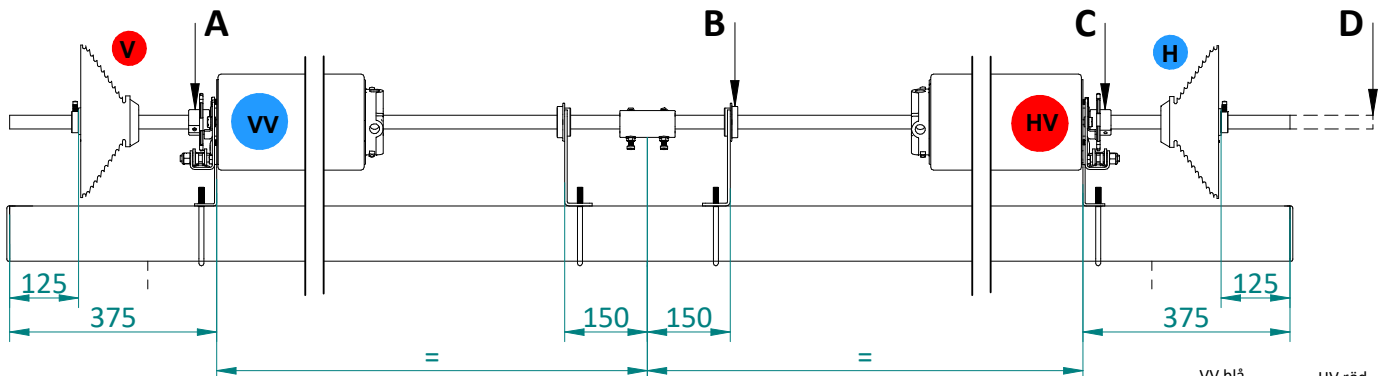

VSK
Topplacerad

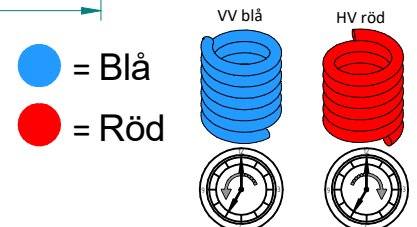
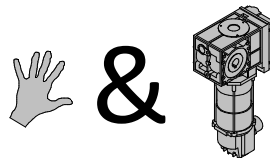

	A	B	C	D
SE	FBS VV eller Lagerstöd + lager	Vid DMB > 4750mm	FBS HV eller Lagerstöd + lager + låsring	Motordrift V eller H
EN	SBD LHW or Bearing plate + bearing + shaft collar	When DLW > 4750mm	SBD RHW or Bearing plate + bearing + shaft collar	Motor operated L or R
DE	FBS LHW oder Lagerkonsole + lager + stelling	Wenn TLB > 4750mm	FBS RHW oder Lagerkonsole + lager + stelling	Antriebe L oder R
FR	Pare-chute ressort LHW ou palier + roulement + baque d'arrêt	LDB > 4750mm	Pare-chute ressort RHW ou palier + roulement + baque d'arrêt	Motorisée D ou G

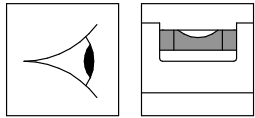
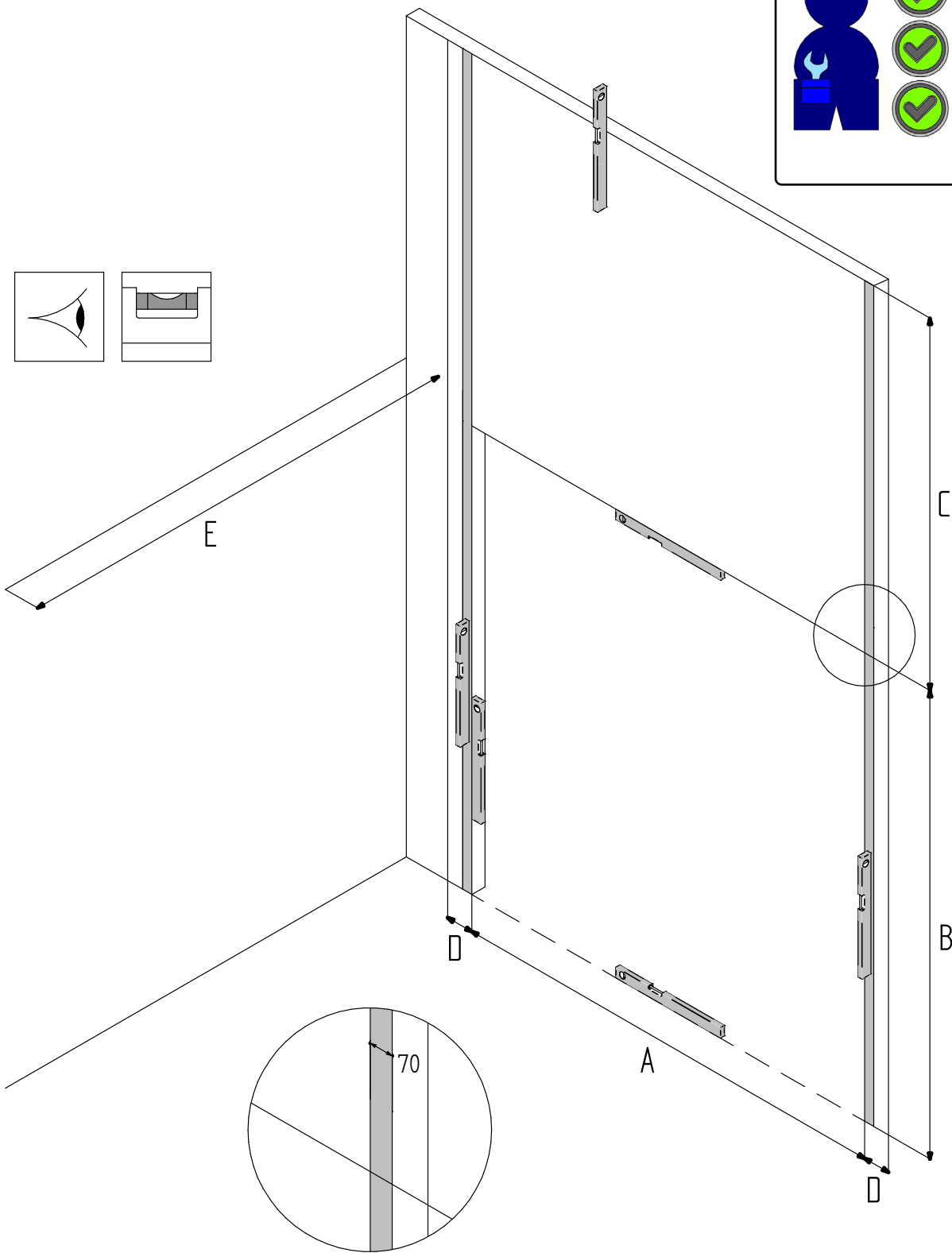
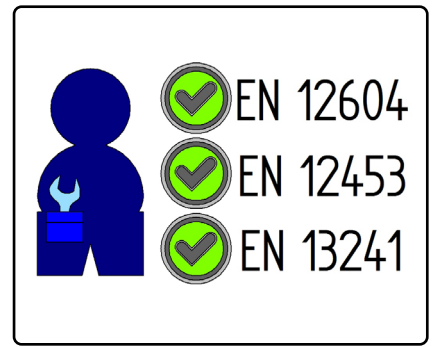

	A	B	C	D	E
	DLW	DLH	FHR	FSR	FMD
NL	Dagmaat breedte	Dagmaat hoogte	Vrije bovenruimte	Vrije zijruimte	Inbouwdiepte
EN	Day Light Width	Day Light Height	Free Head Room	Free Side Room	Free Mounting Depth
DE	Tageslichtbreite	Tageslichtehöhe	Sturzfreiraum	Freie Seitenraum	Freie Einbautiefe
FR	Largeur de baie	Hauteur de baie	Linéau disponible	Ecoinçons Requis	Recul
RO	Lățime Gol	Înălțime Gol	Buiandrug Liber	Spațiul Liber Lateral	Spațiul Liber în Adâncime
HU	Szélesség	Magasság	Szabad szemöldök magasság	Szabad hely oldalt	Szabad beépítési mélység
SE	Dagmåttsbredd	Dagmåtshöjd	Minsta erforderligt höjdutrymme	Fritt sidoutrymme	Fritt monterings utrymme

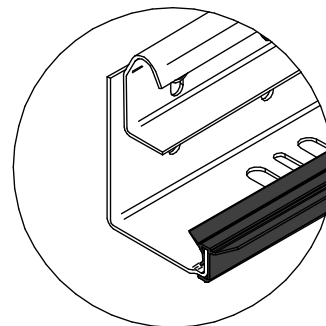
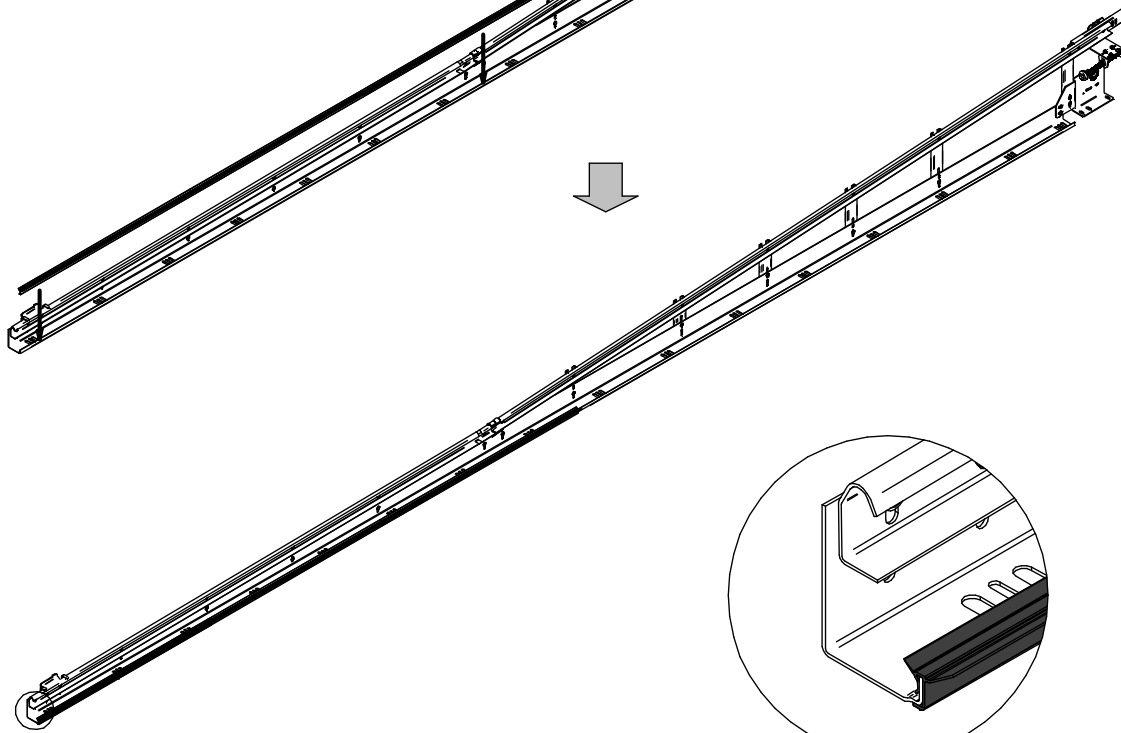
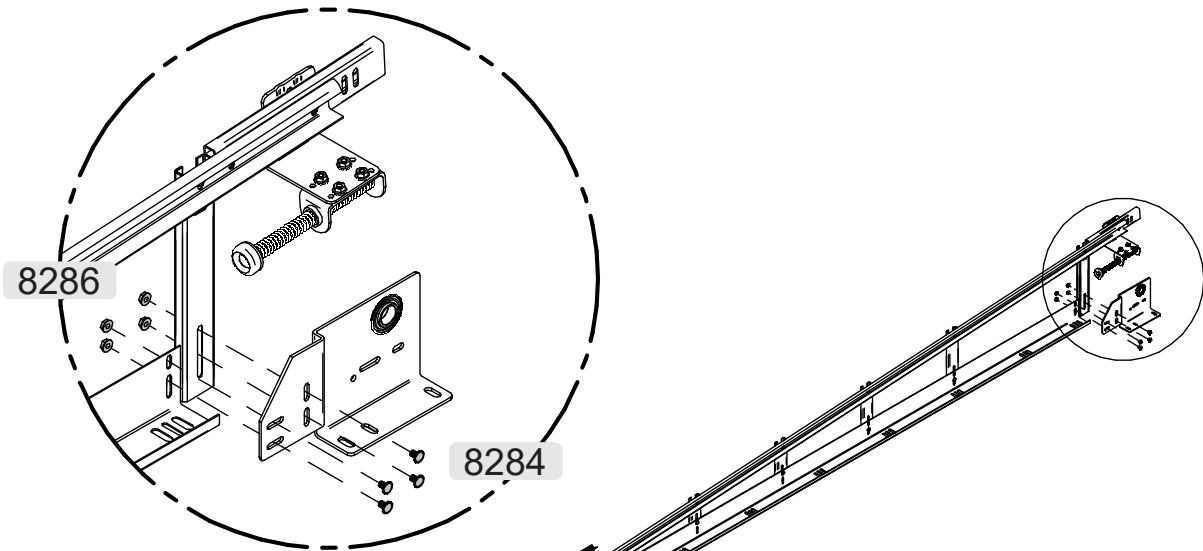
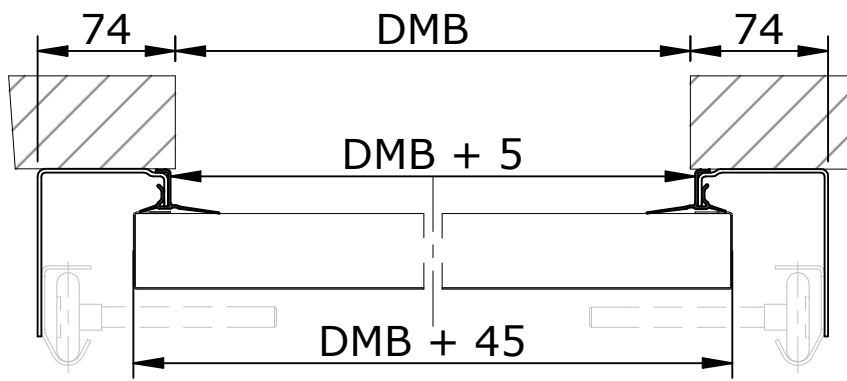

3199

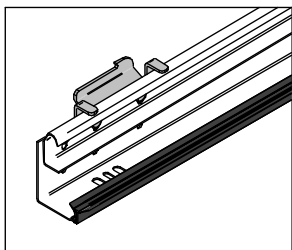

Option 80mm ISO

3280, 3282, 3290

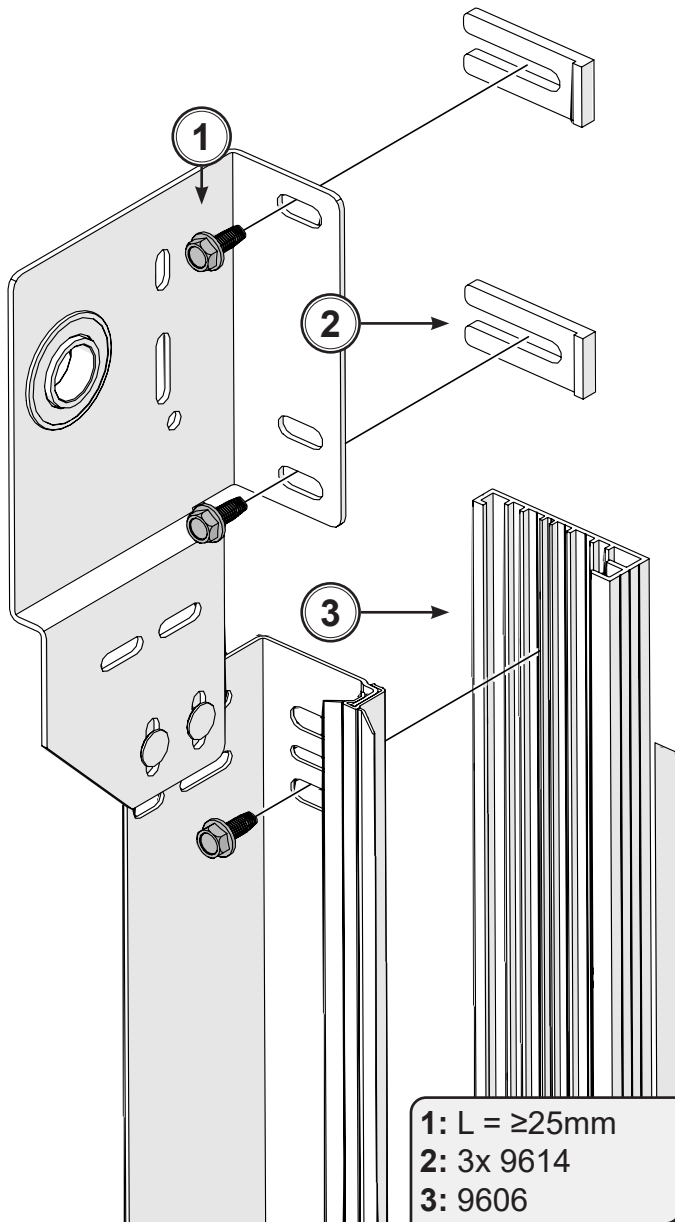

3284, 3286, 3292,
3294, 3296

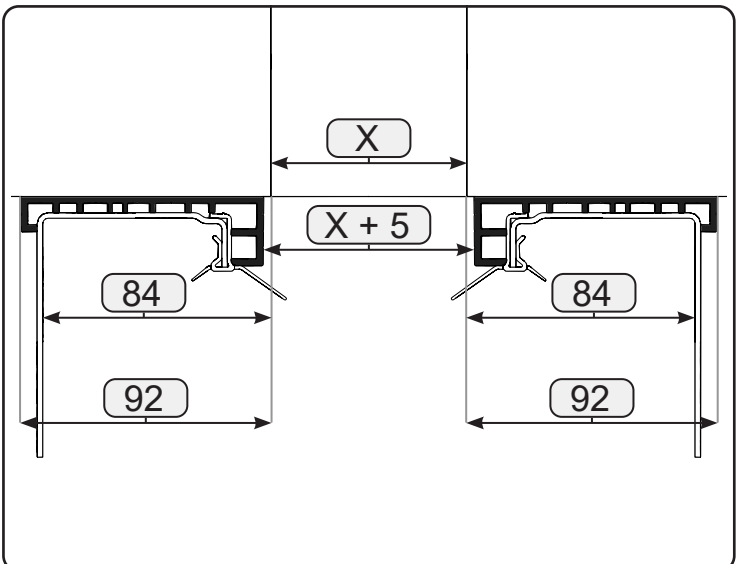
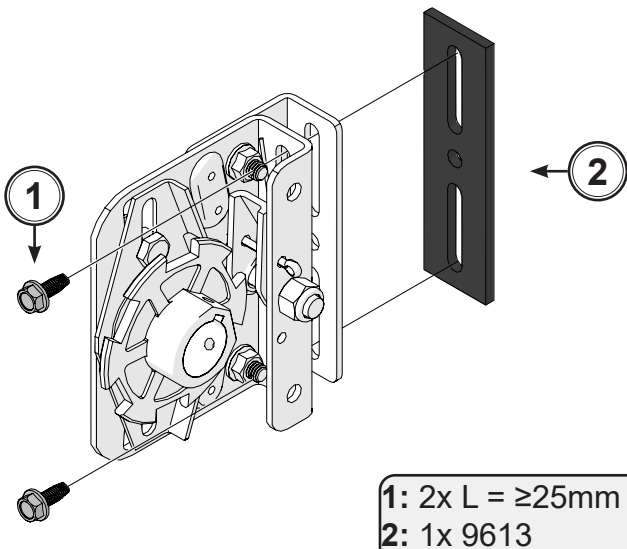
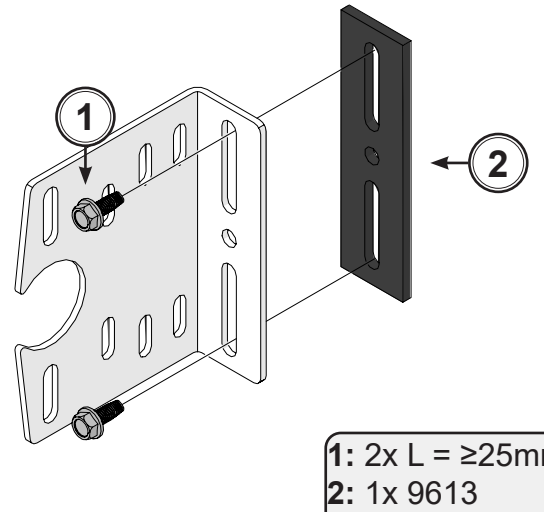
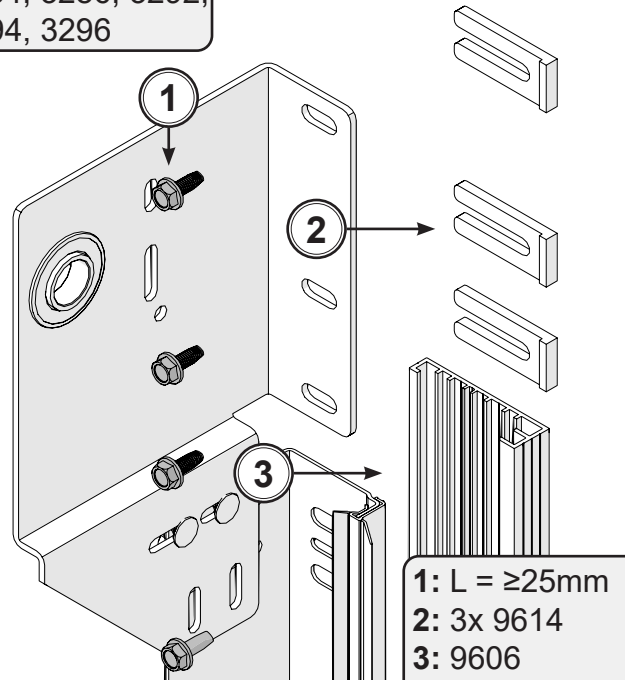

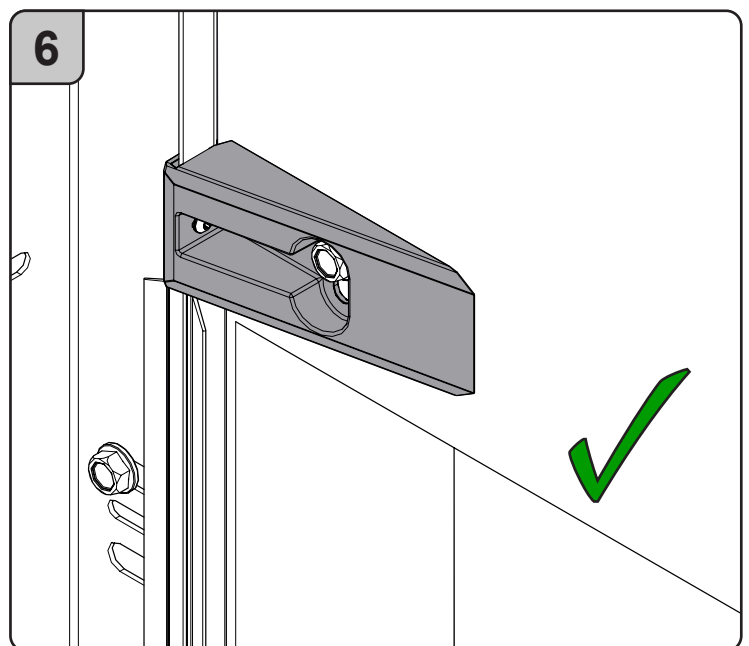
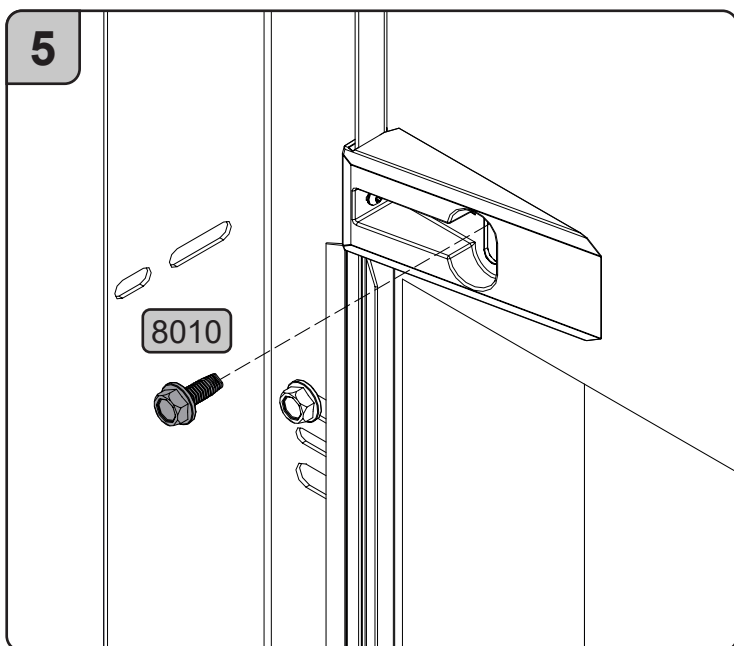
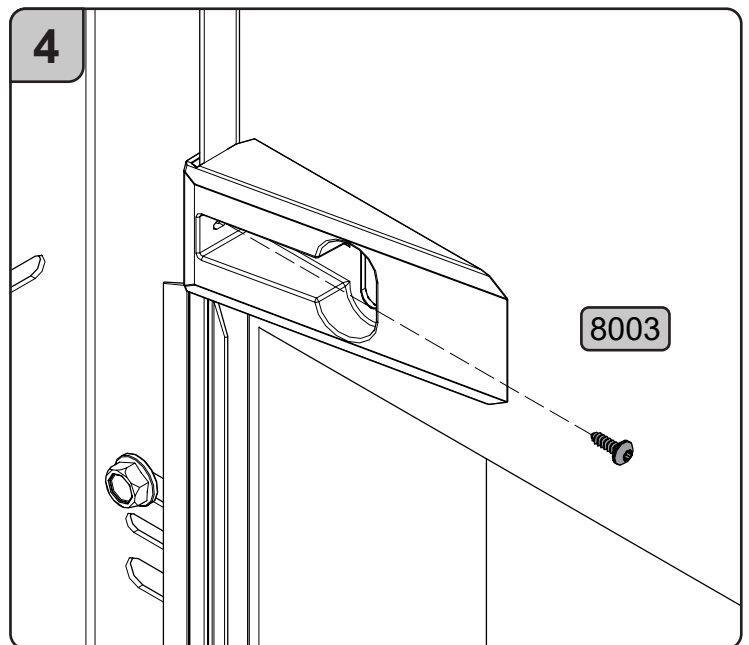
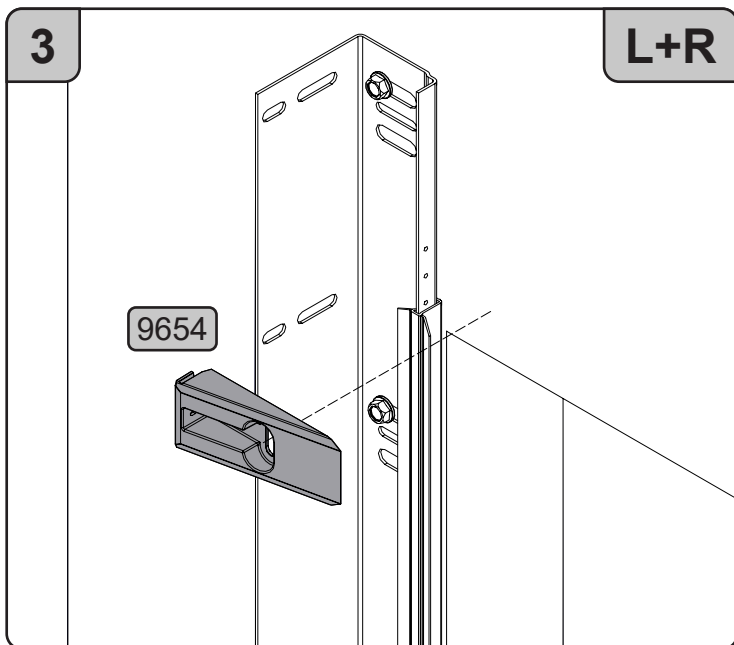
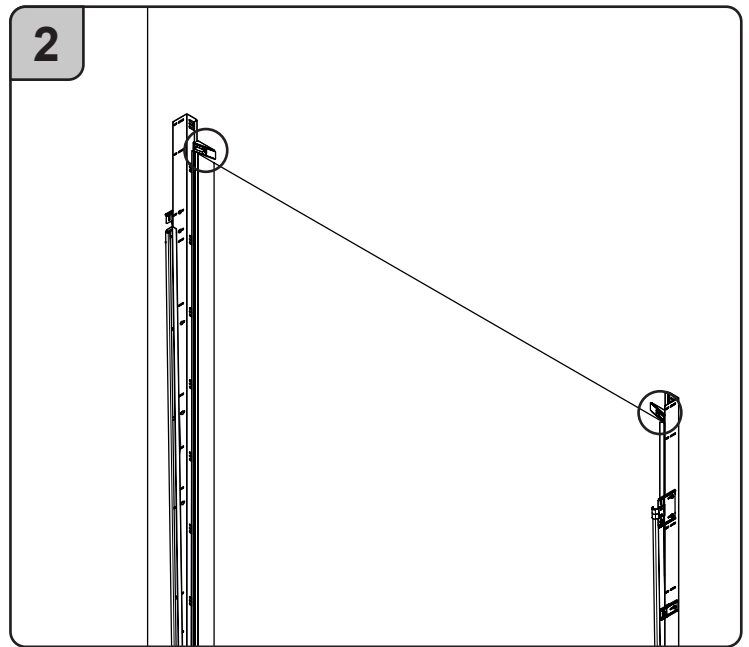
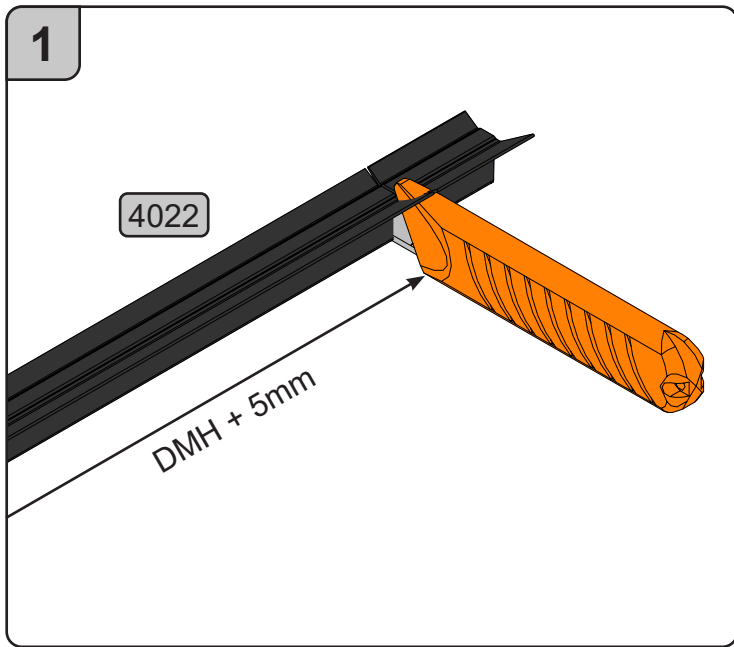

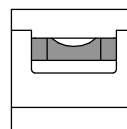
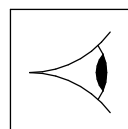
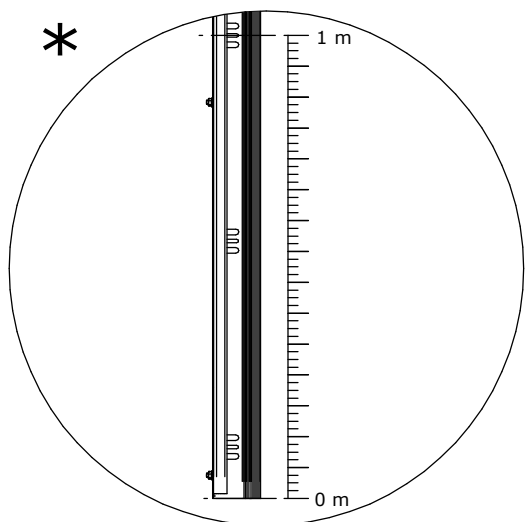
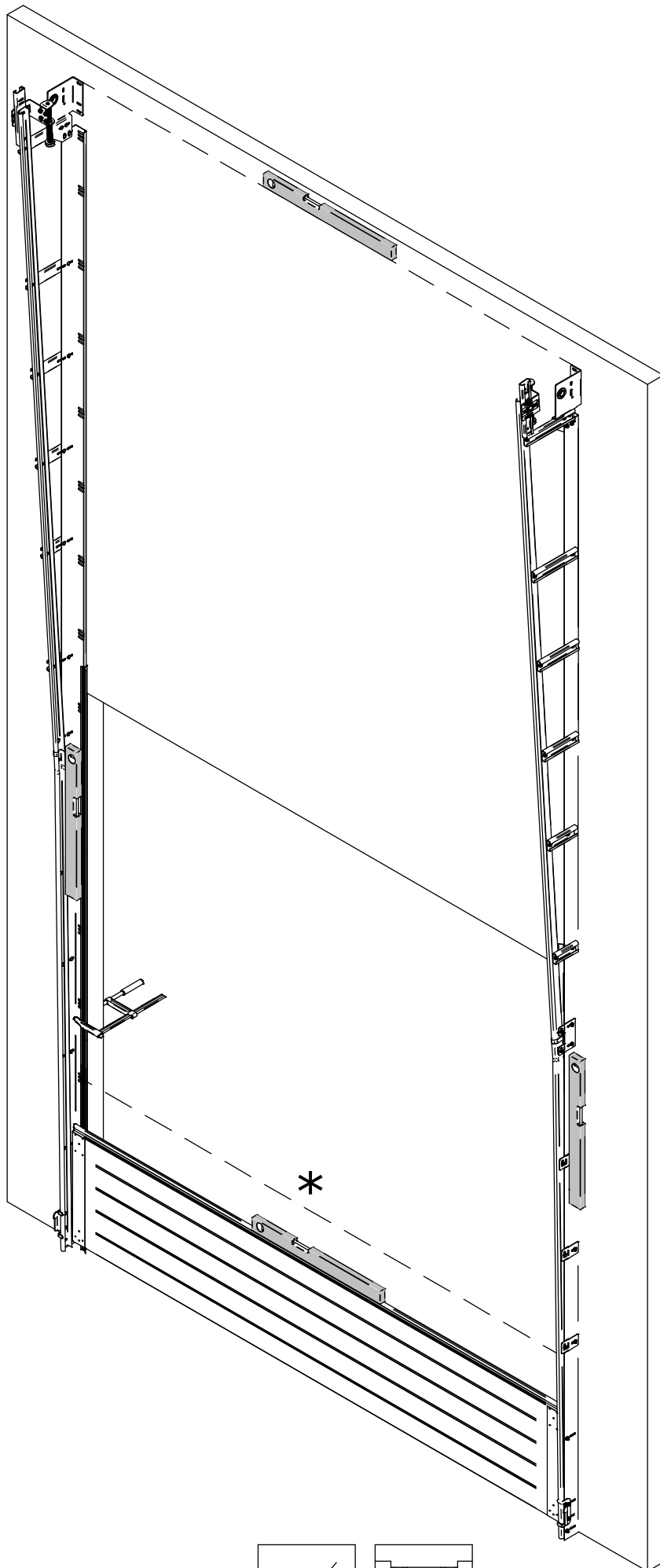

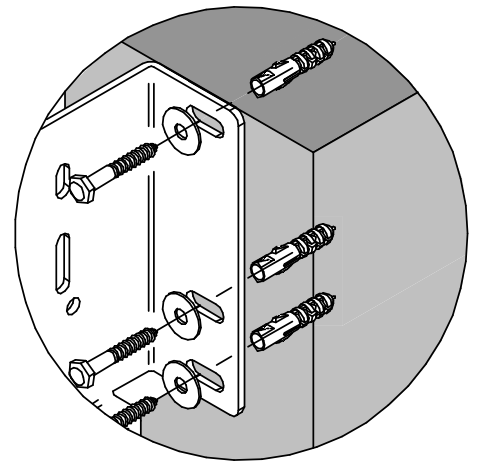
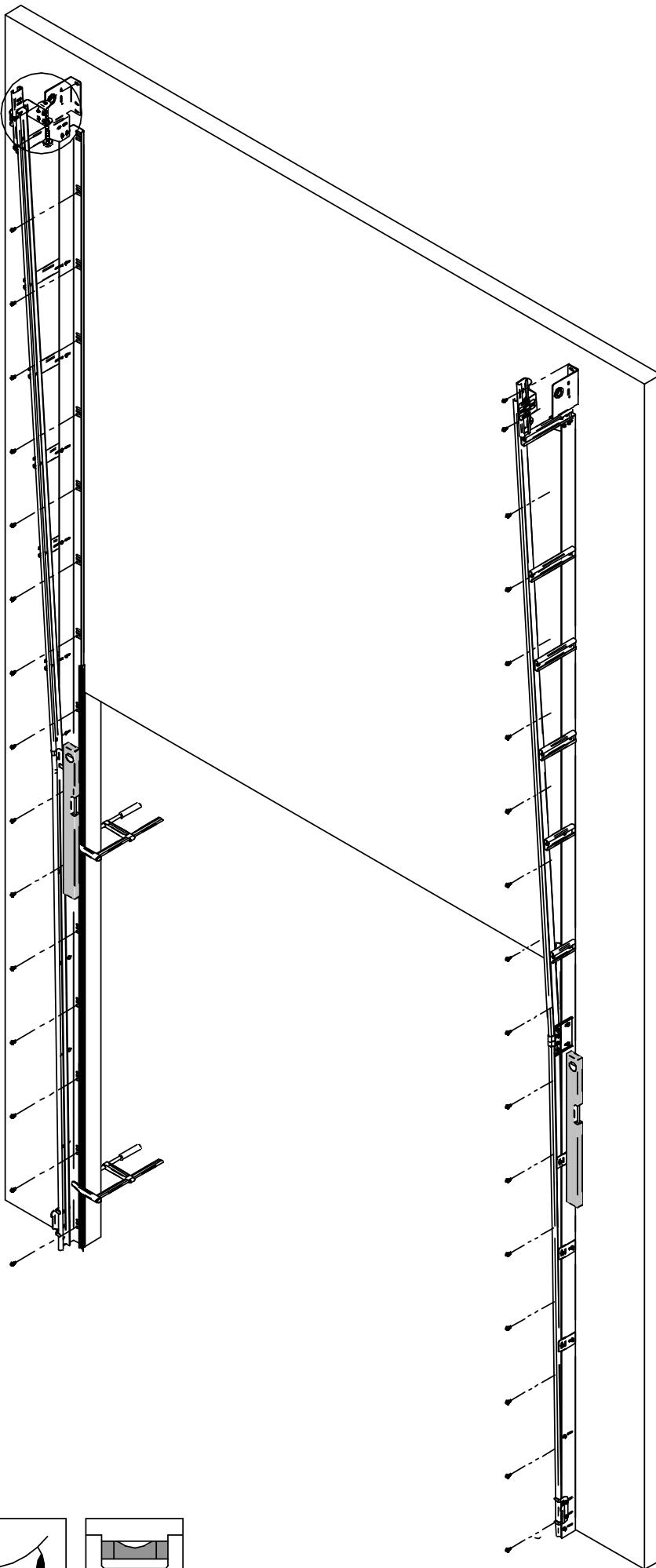

$\phi 10$

0351

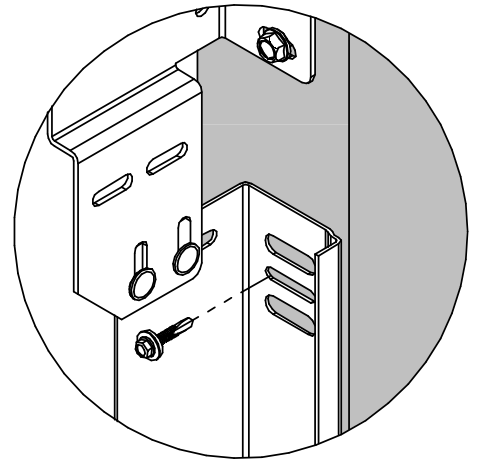

$\phi 6$

8011

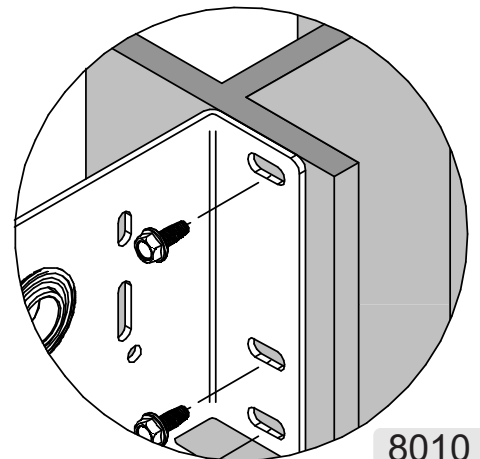

$\phi 8$

8010

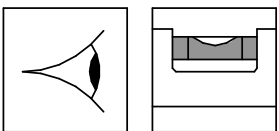

VS

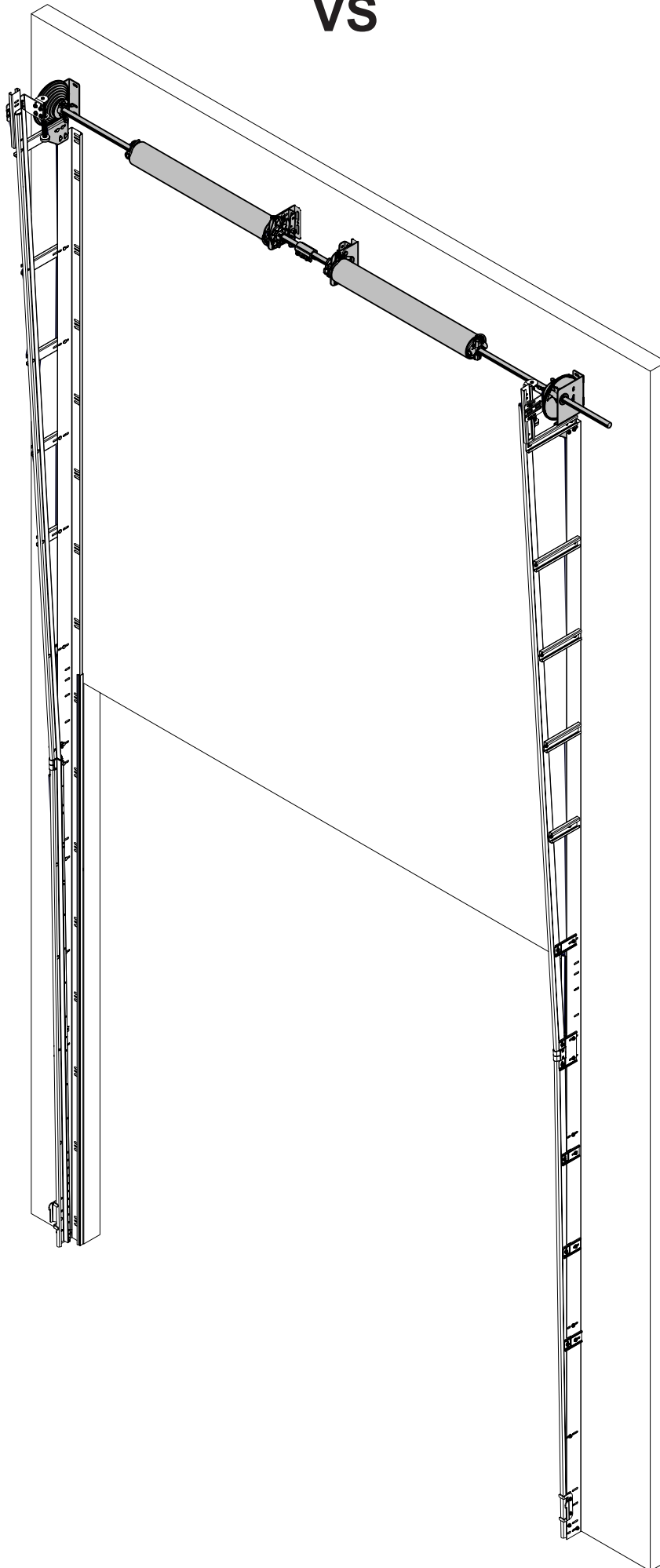

VSK Standard

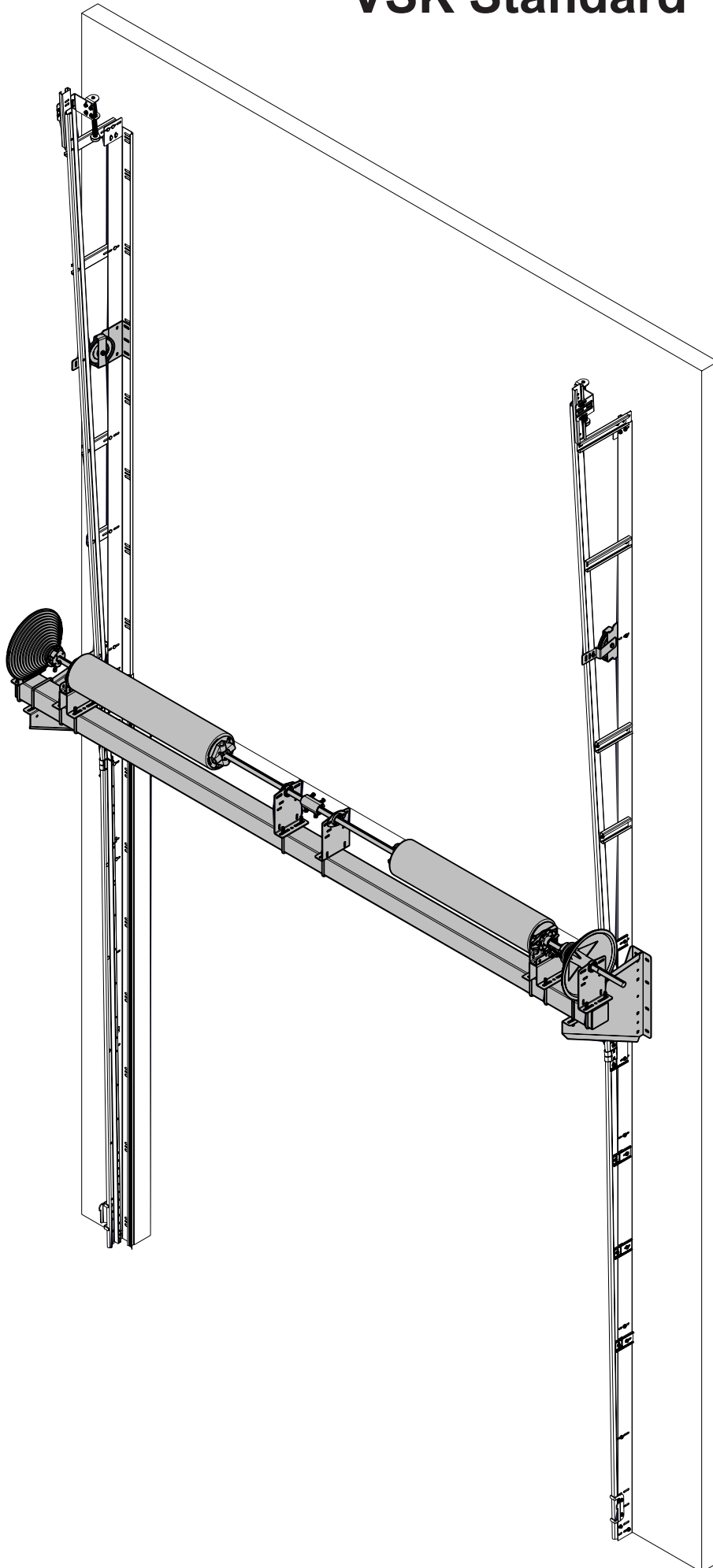

HSK FBS(fjäderbrottskydd)-placering

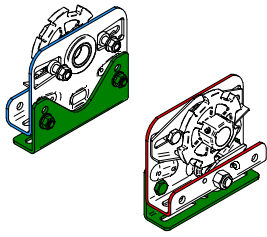
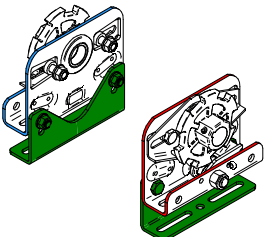
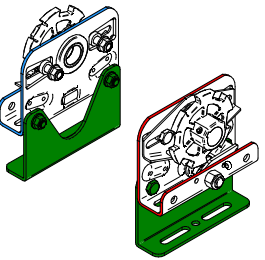
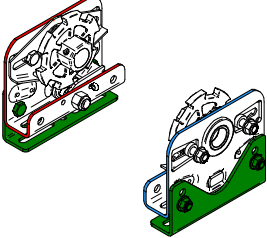
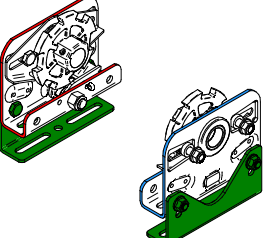
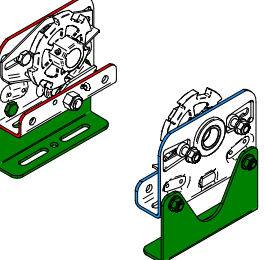
<p>2 fjädrar + 4 fjädrar, ytterfjädrar (duplex)</p>			
	<p>111 - 3164</p>	<p>127 - 3164</p>	<p>152 - 3165</p>
<p>4 fjädrar, innerfjädrar (duplex)</p>			
	<p>111 - 3164</p>	<p>127 - 3164</p>	<p>152 - 3165</p>

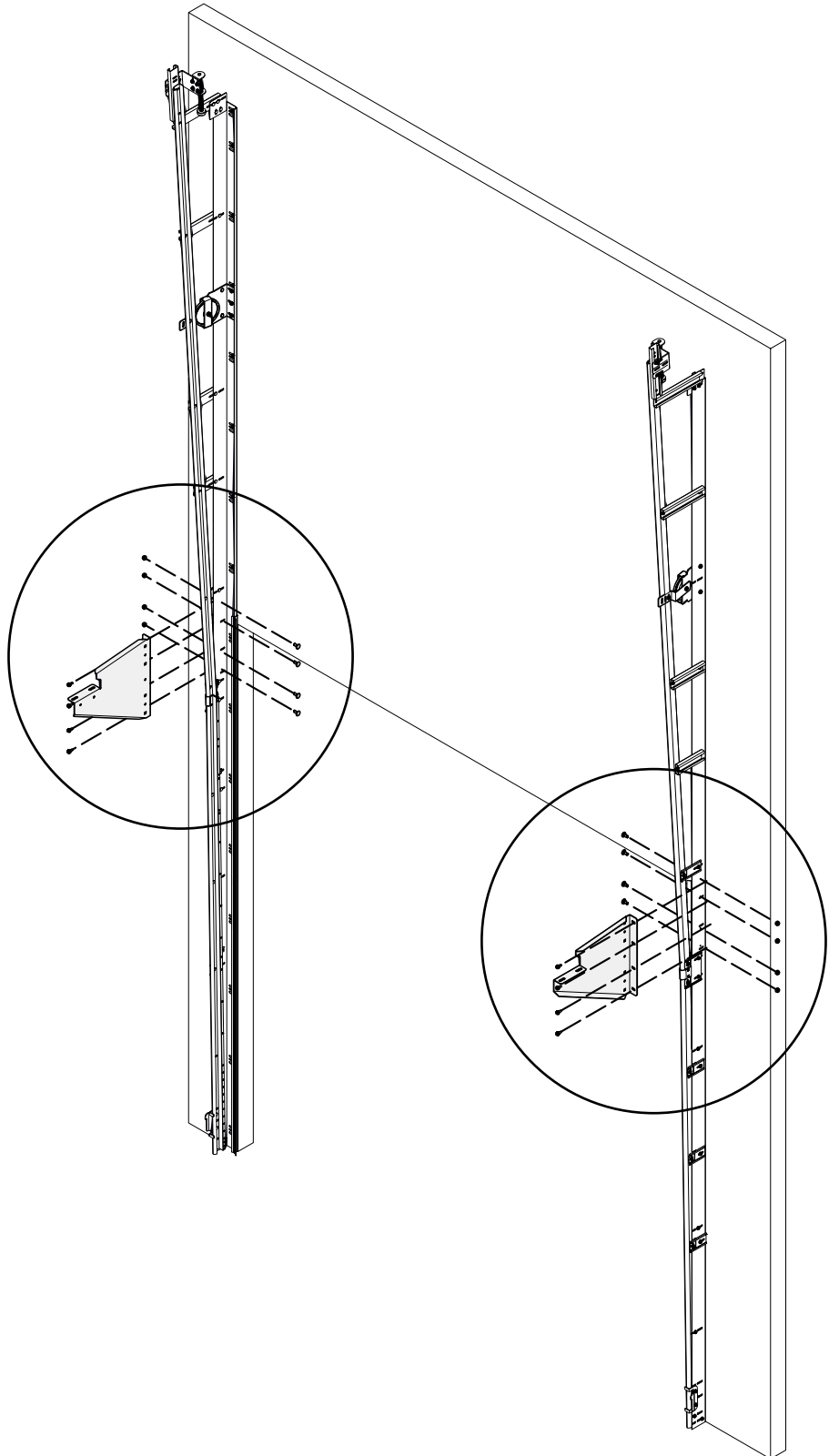
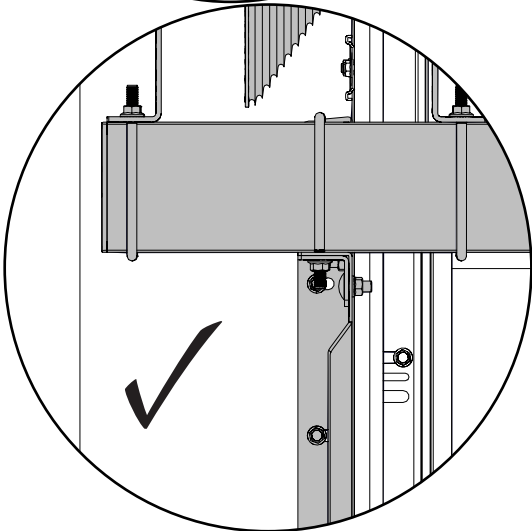
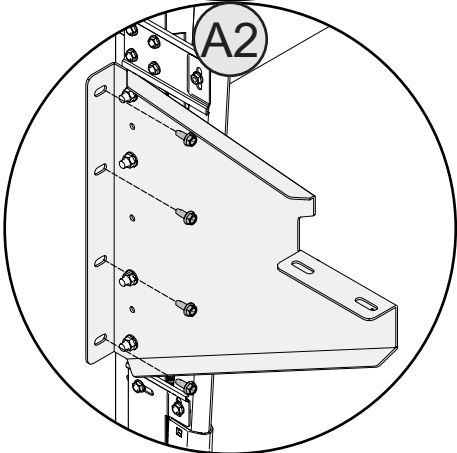
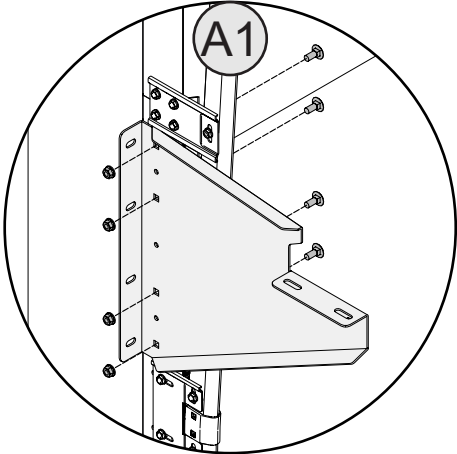
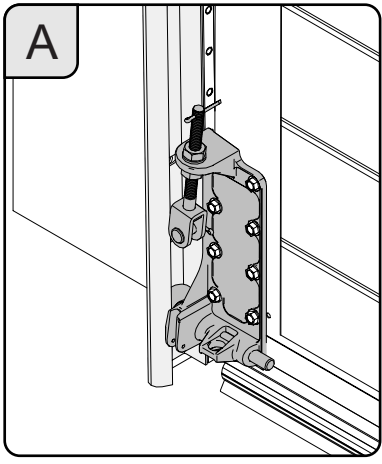

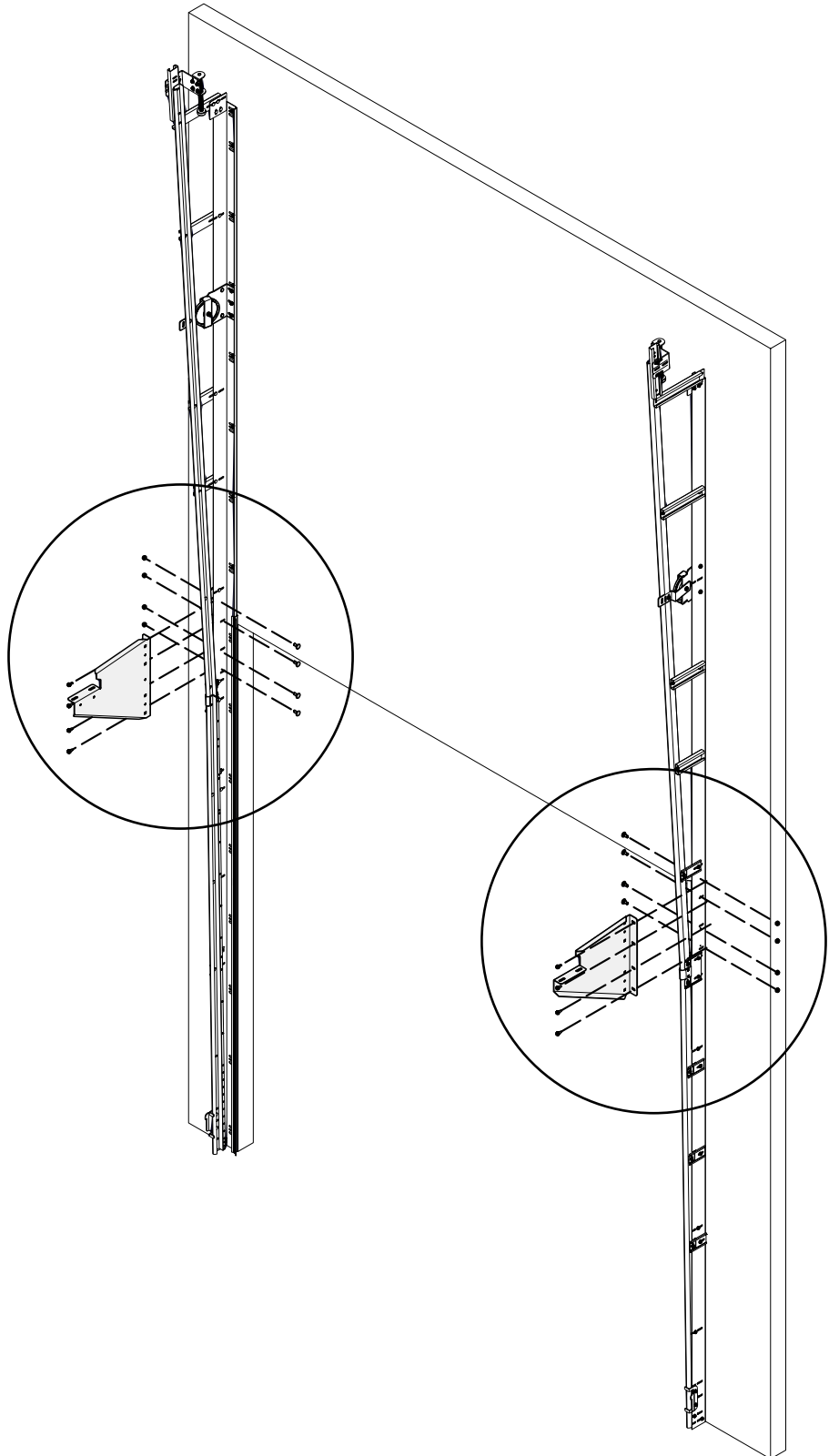
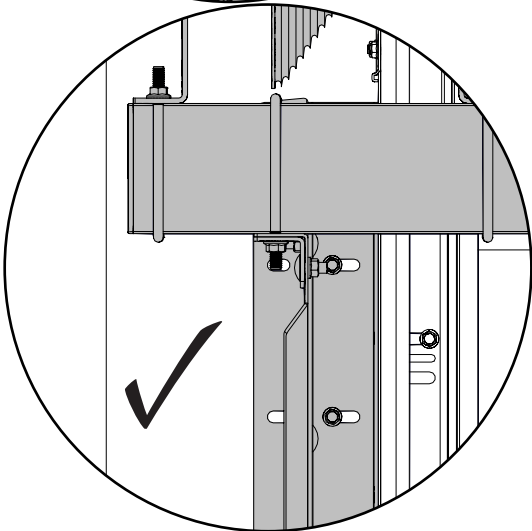
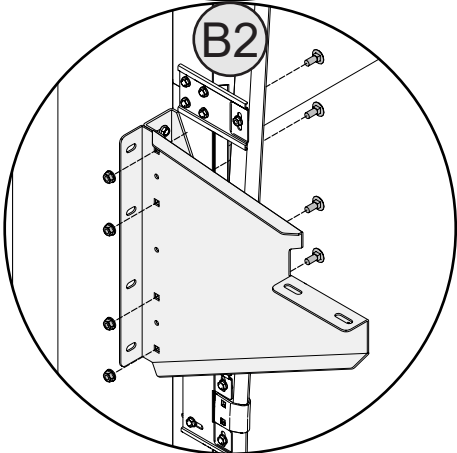
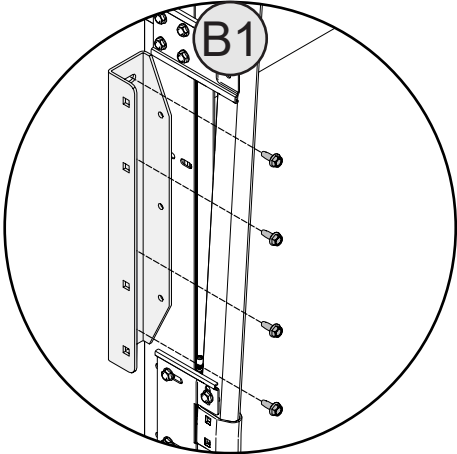
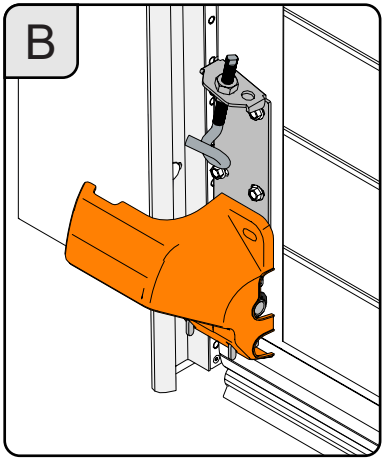

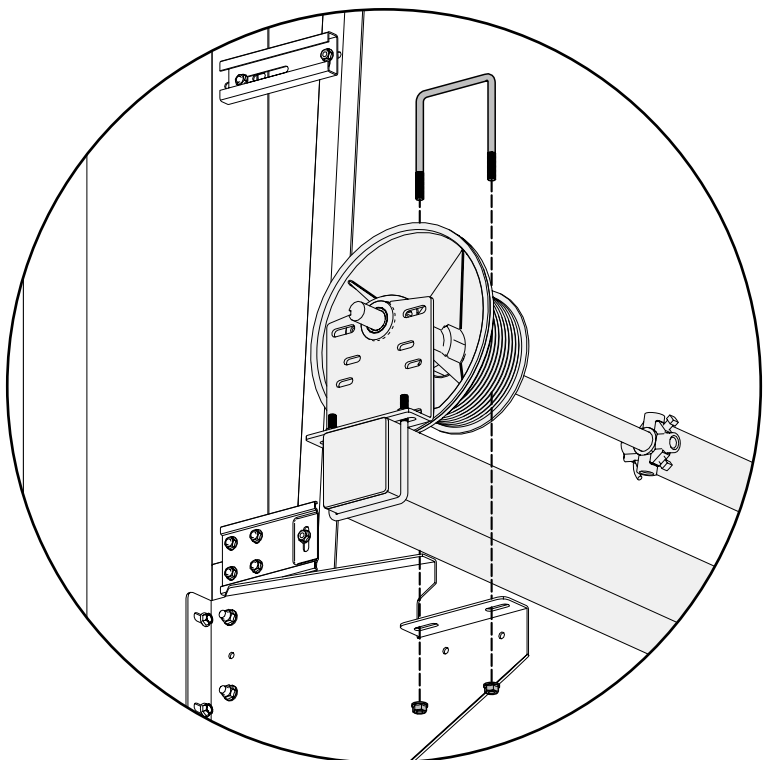
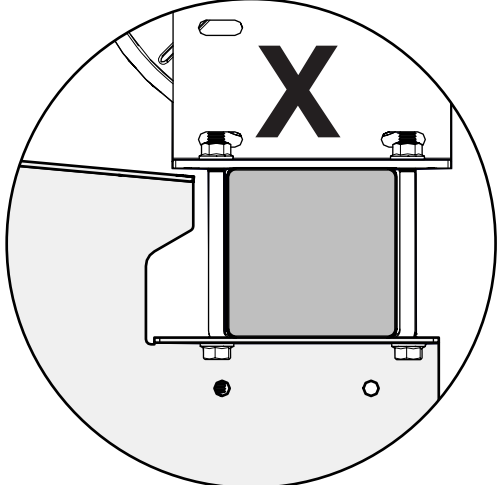
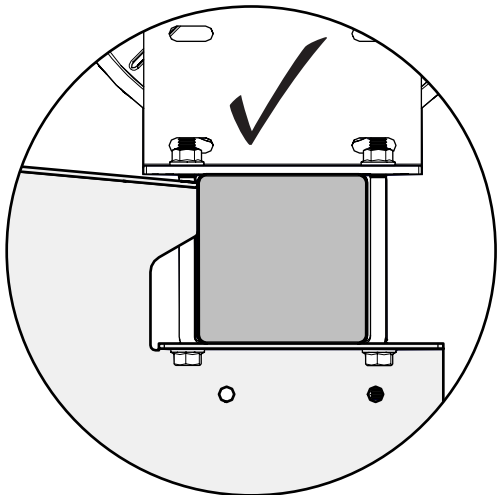
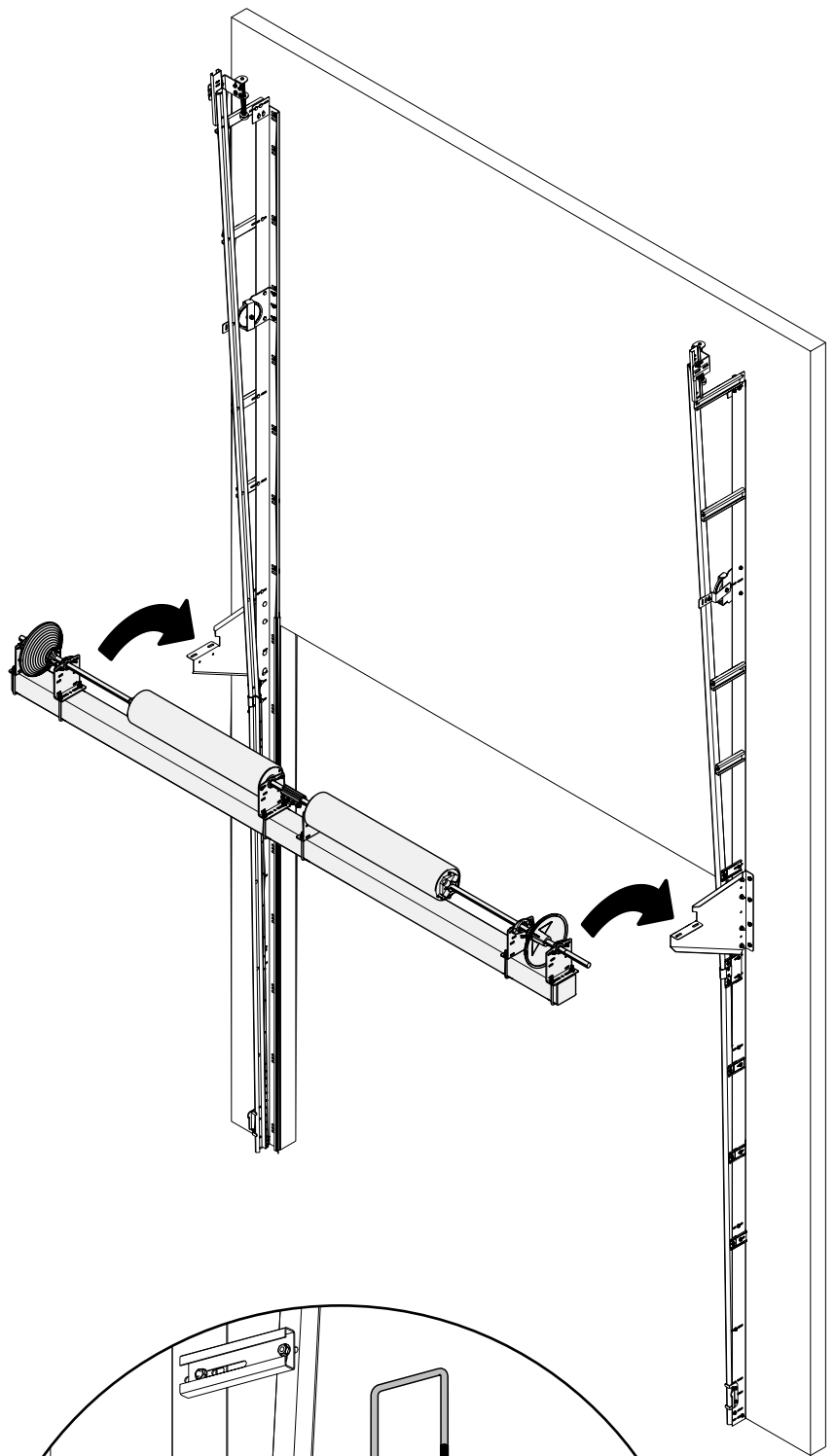

VSK Topp

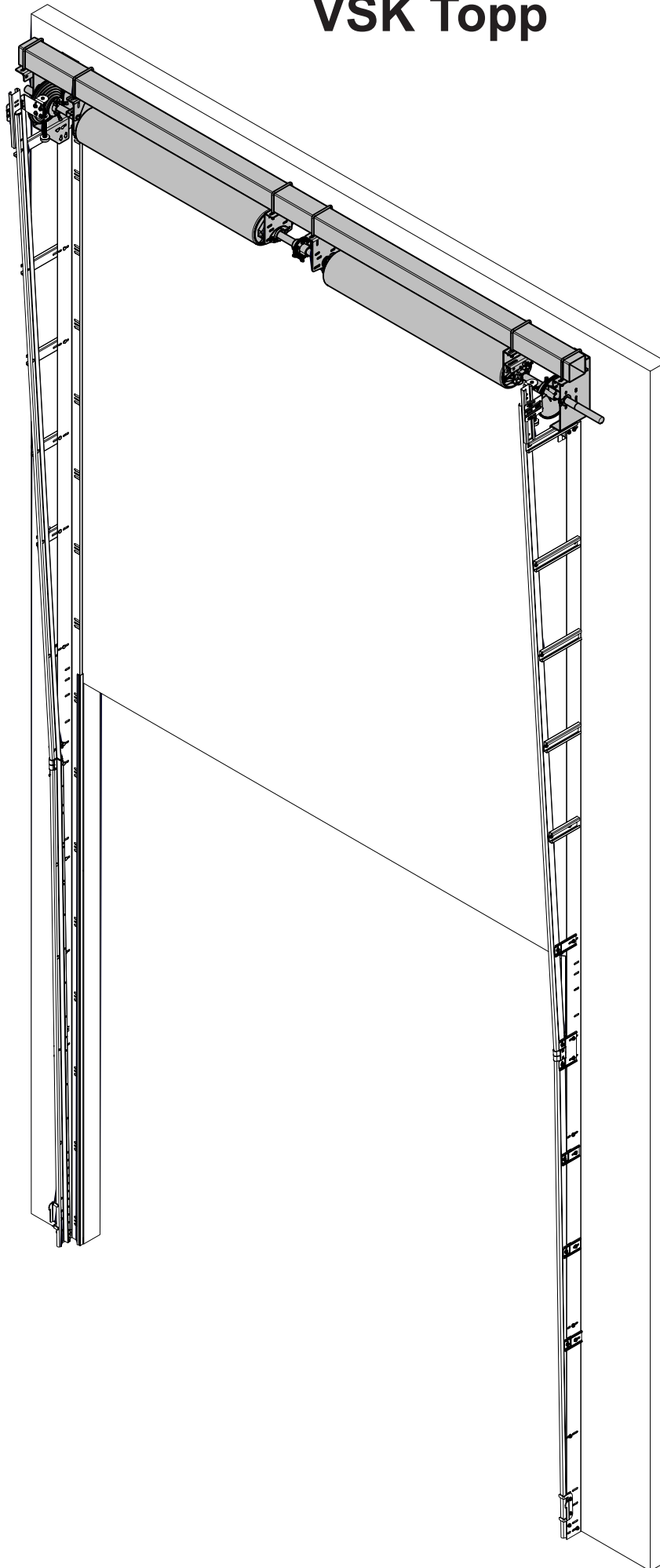

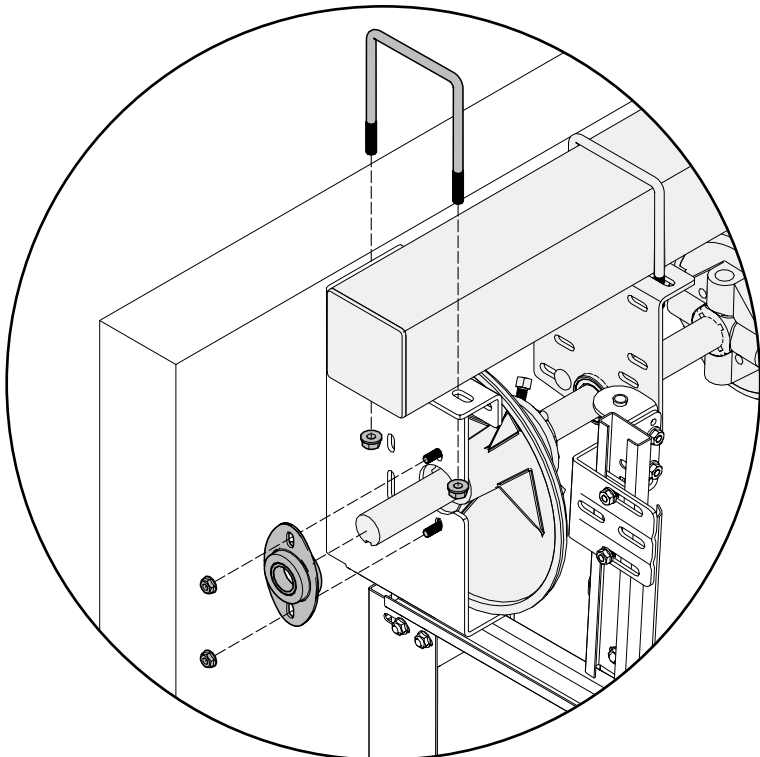
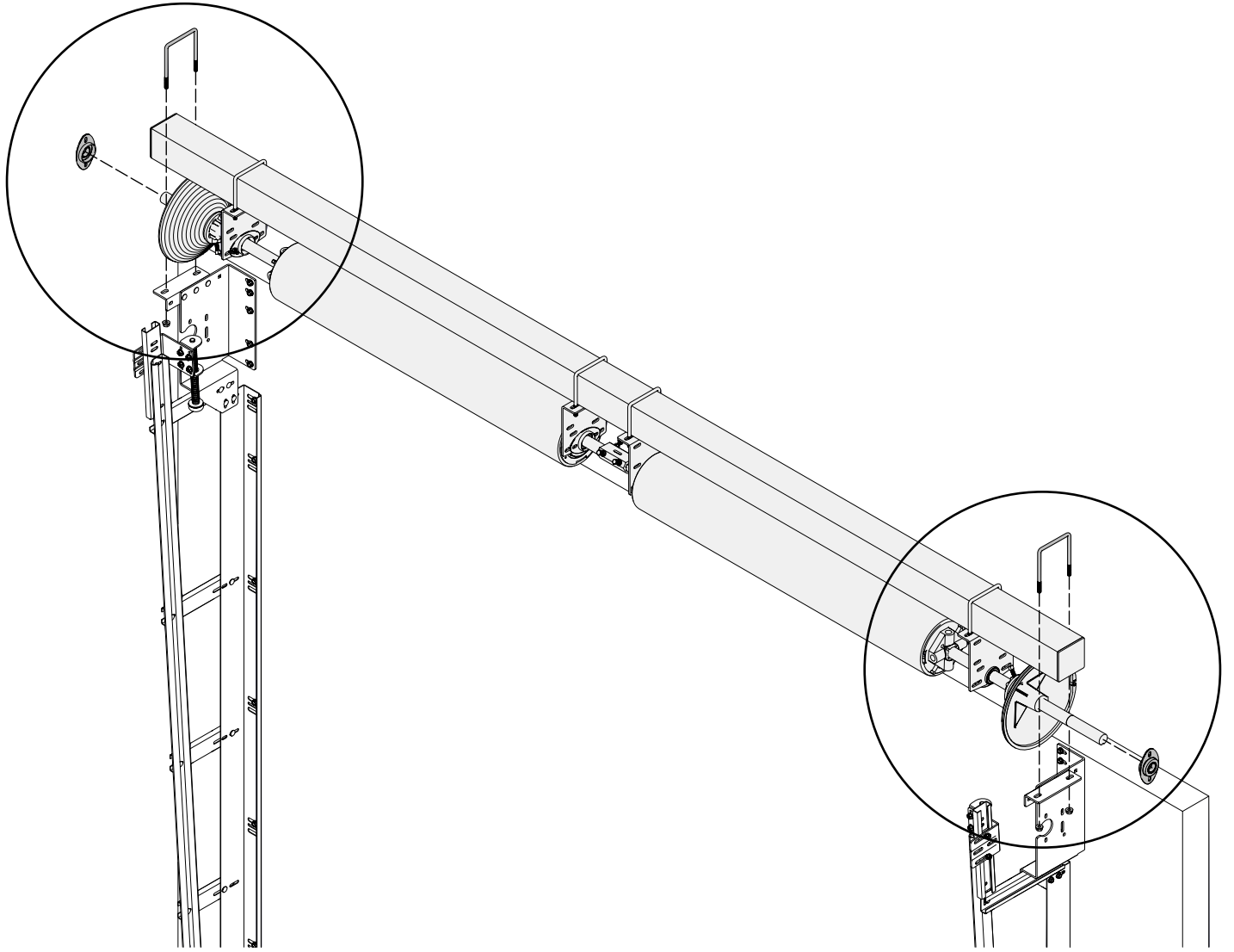

VSK Utvändiga vajrar

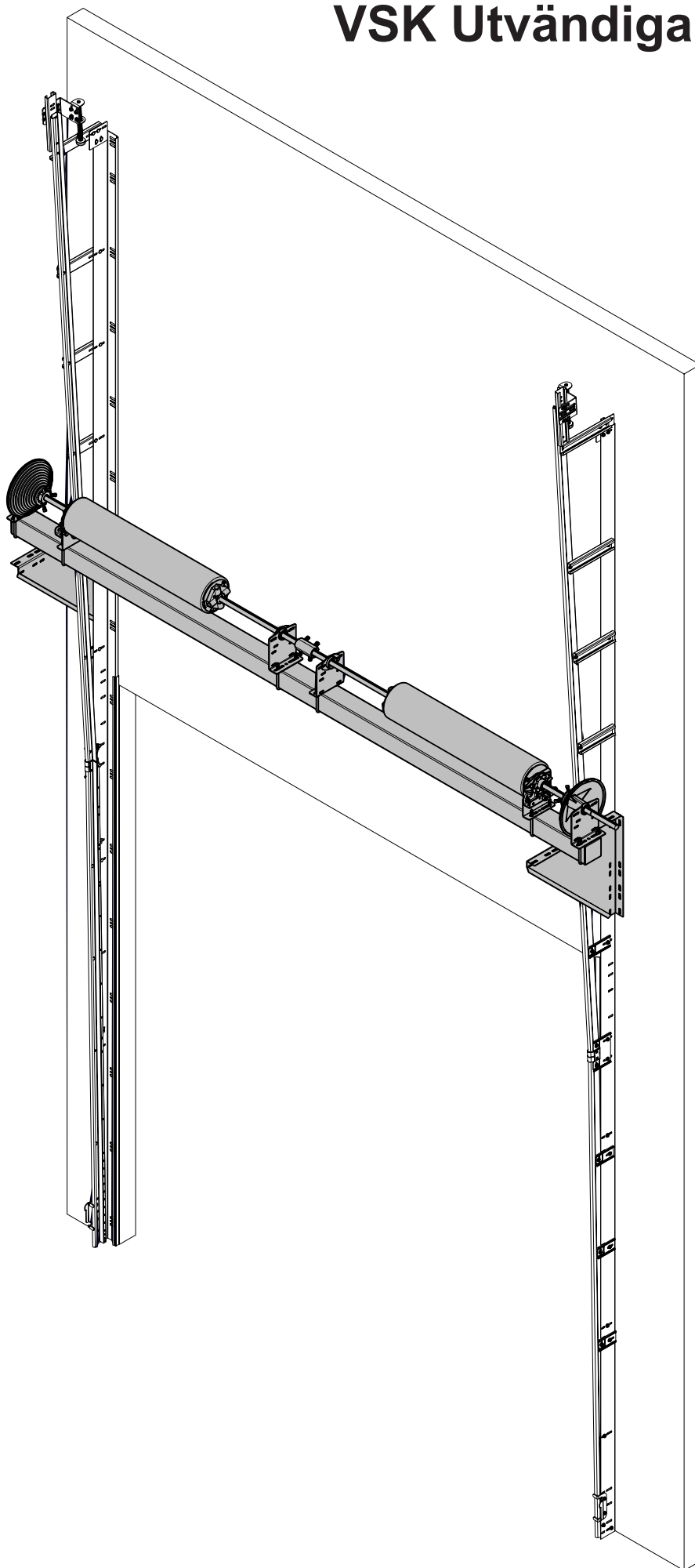

HSK Utvändiga vajrar

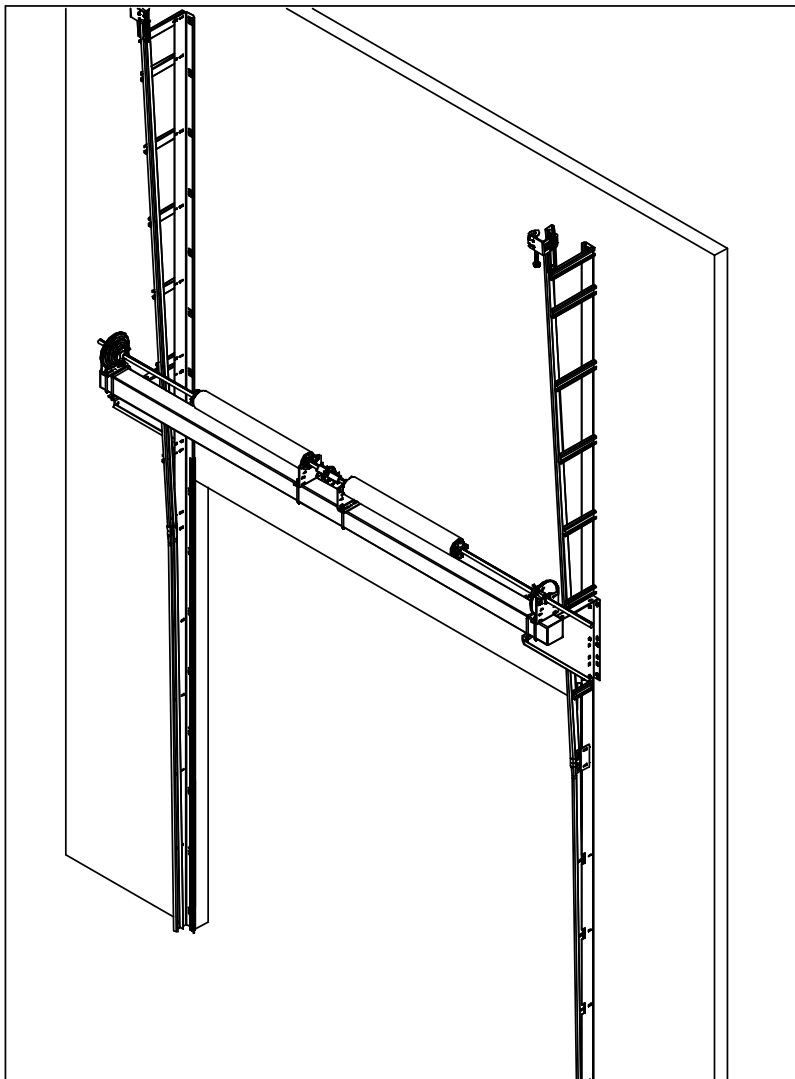
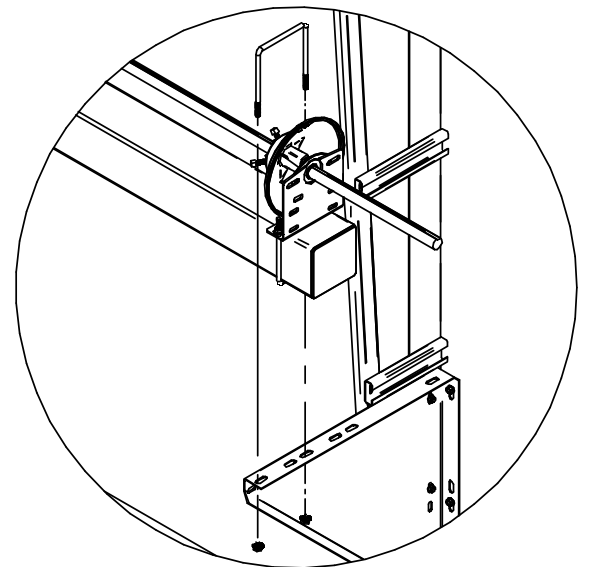
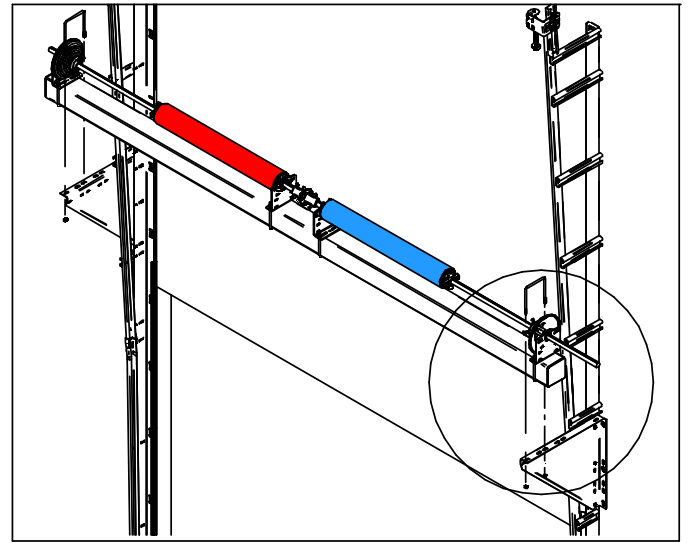
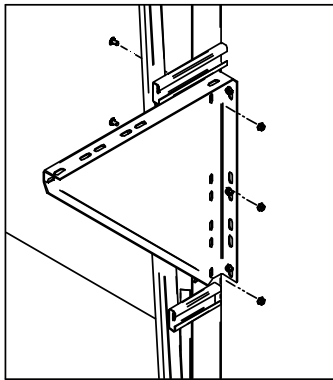
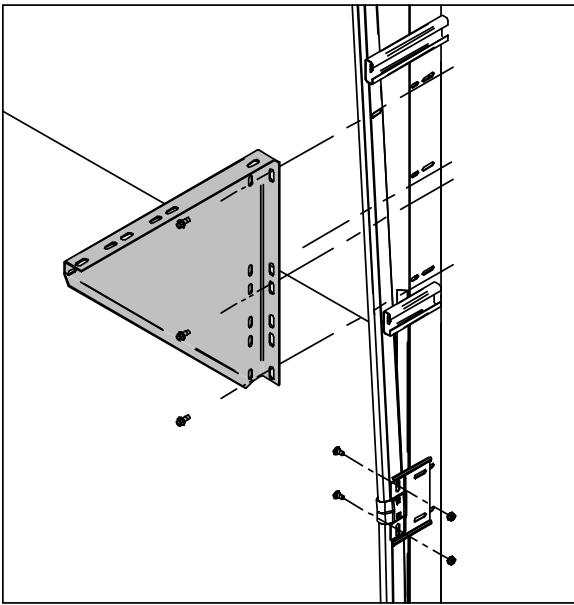

WV

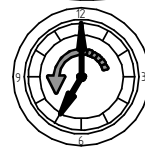
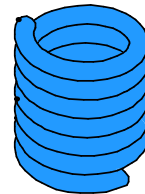

HV

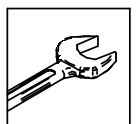
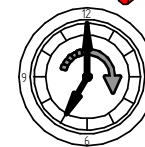
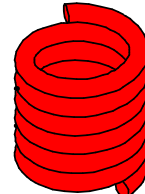

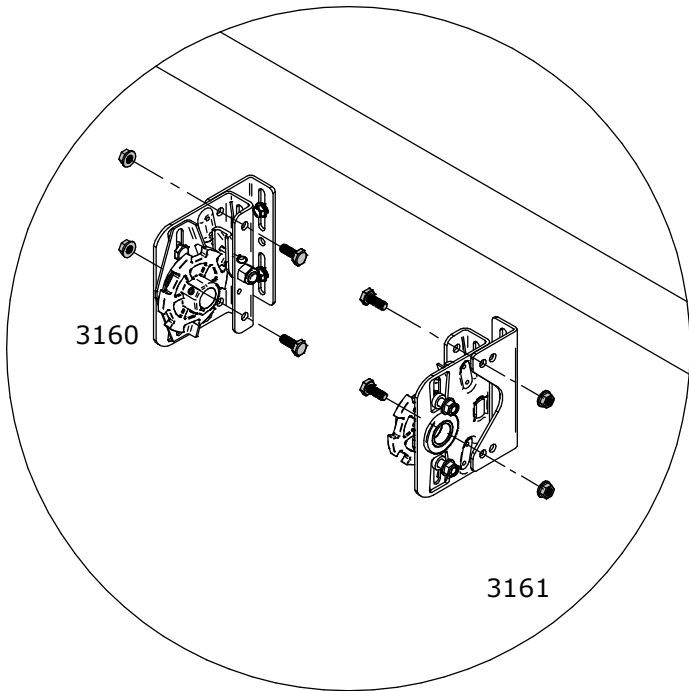
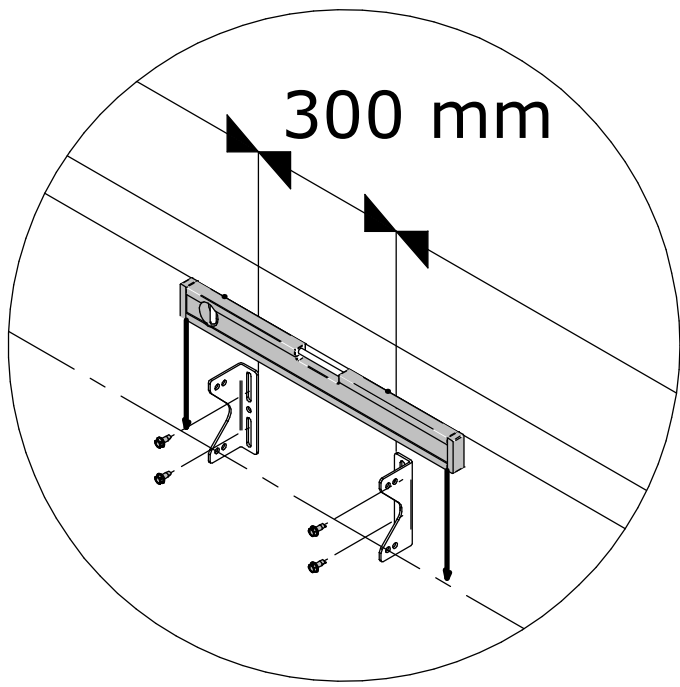

3160

3161

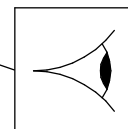
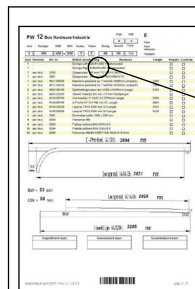
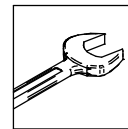
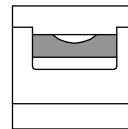
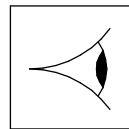
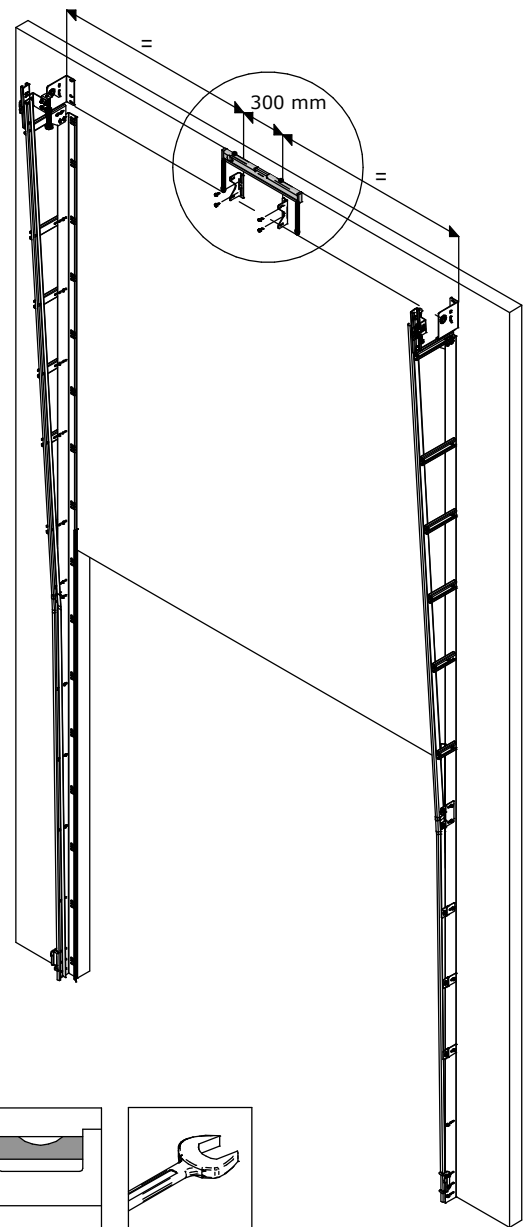
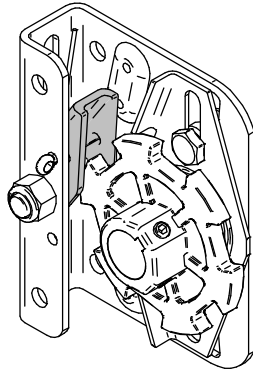
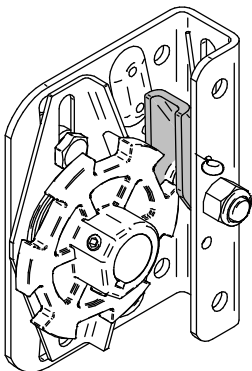

67 mm
95 mm

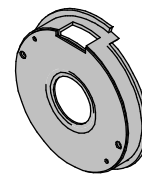

152 mm

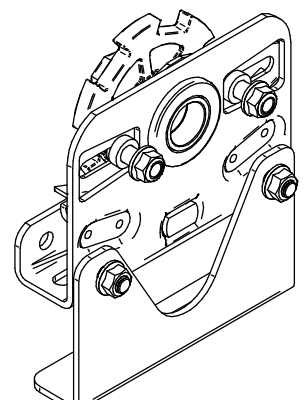
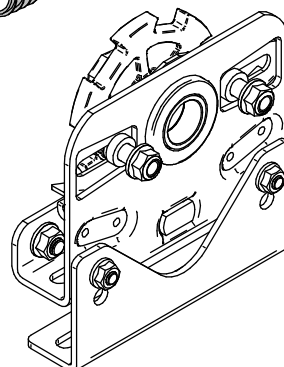

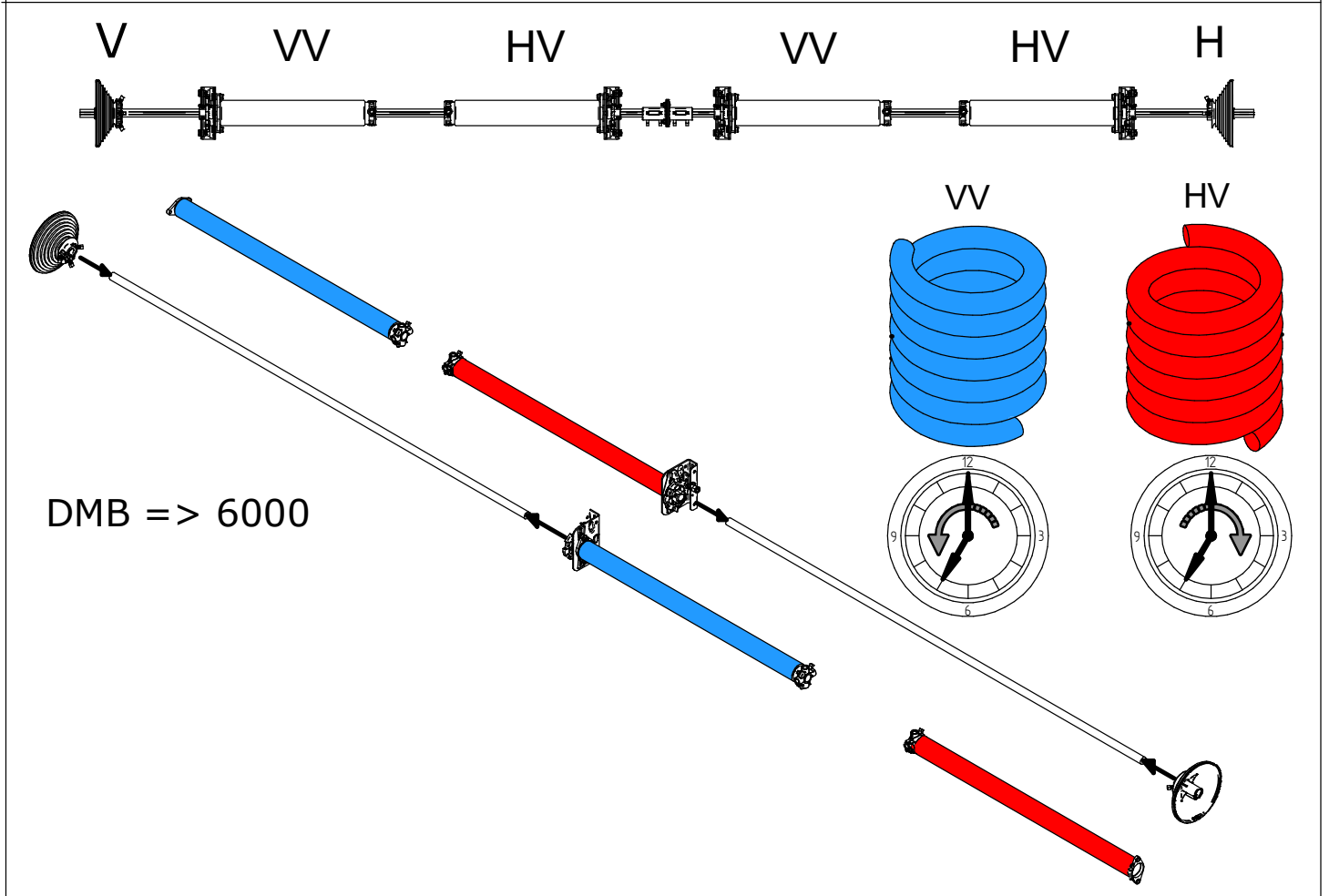
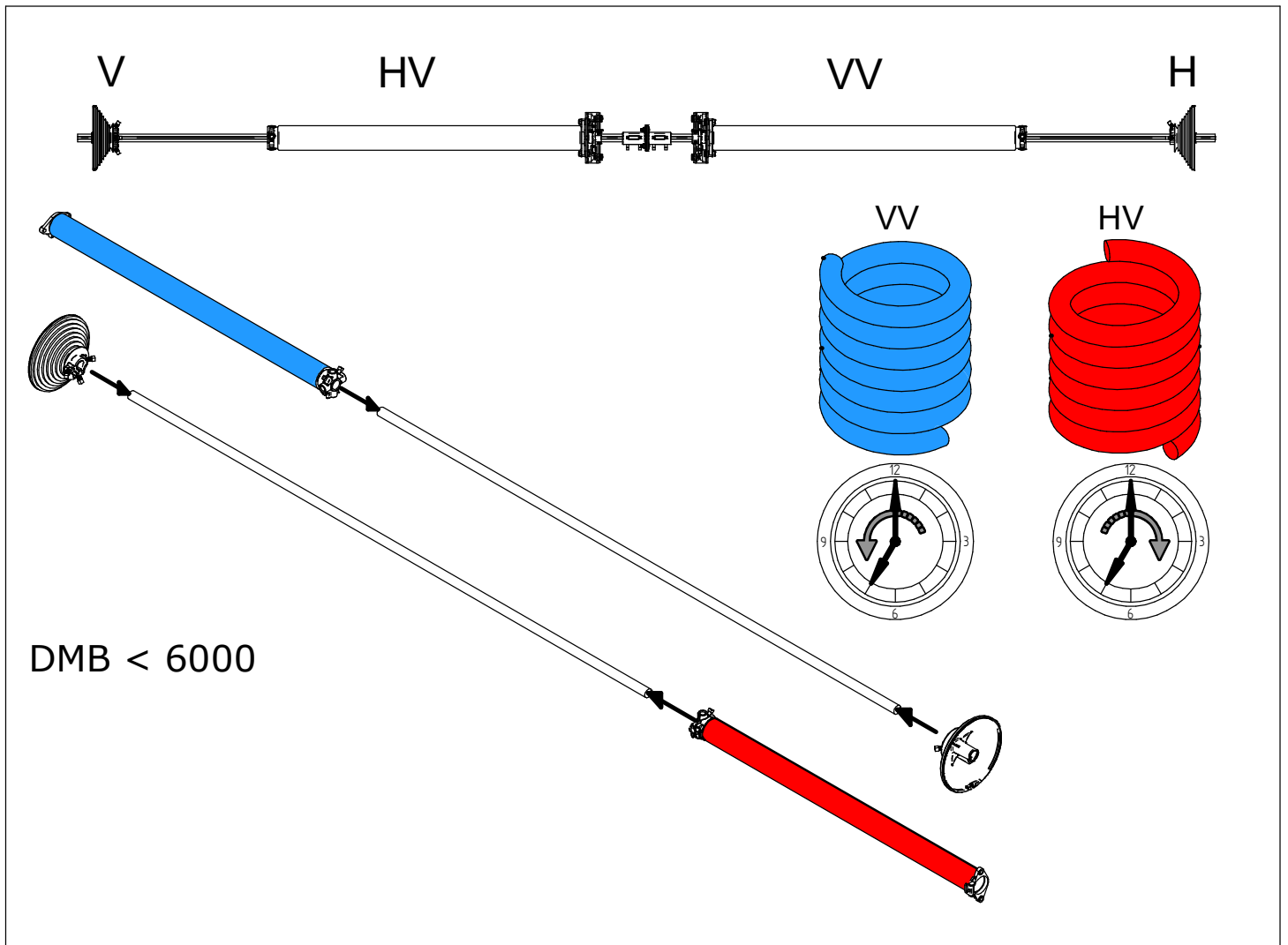

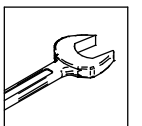
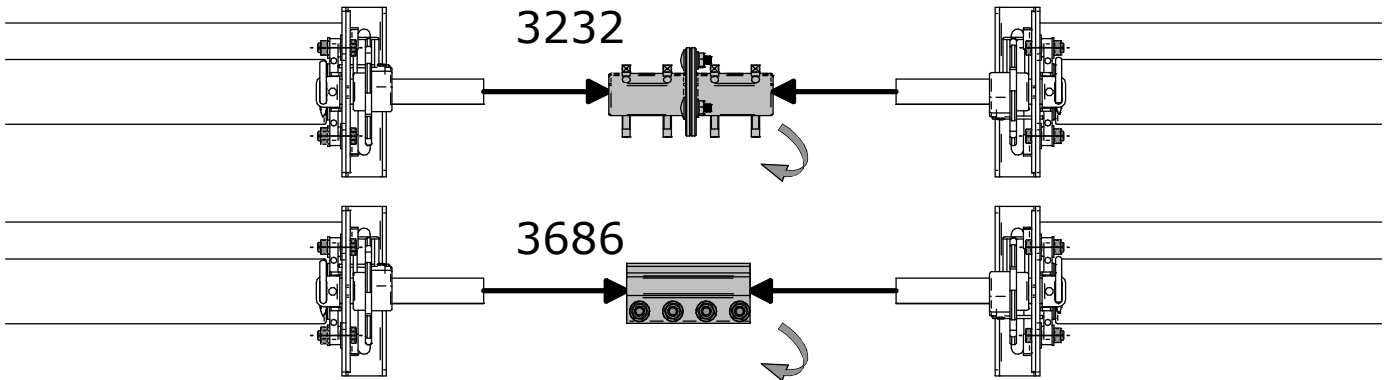
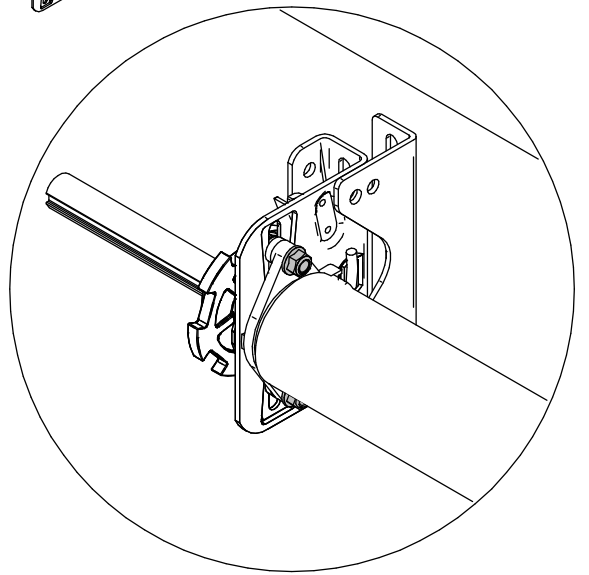
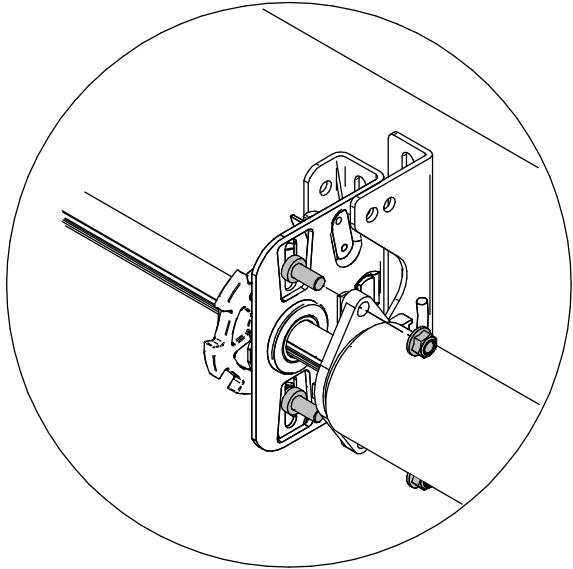
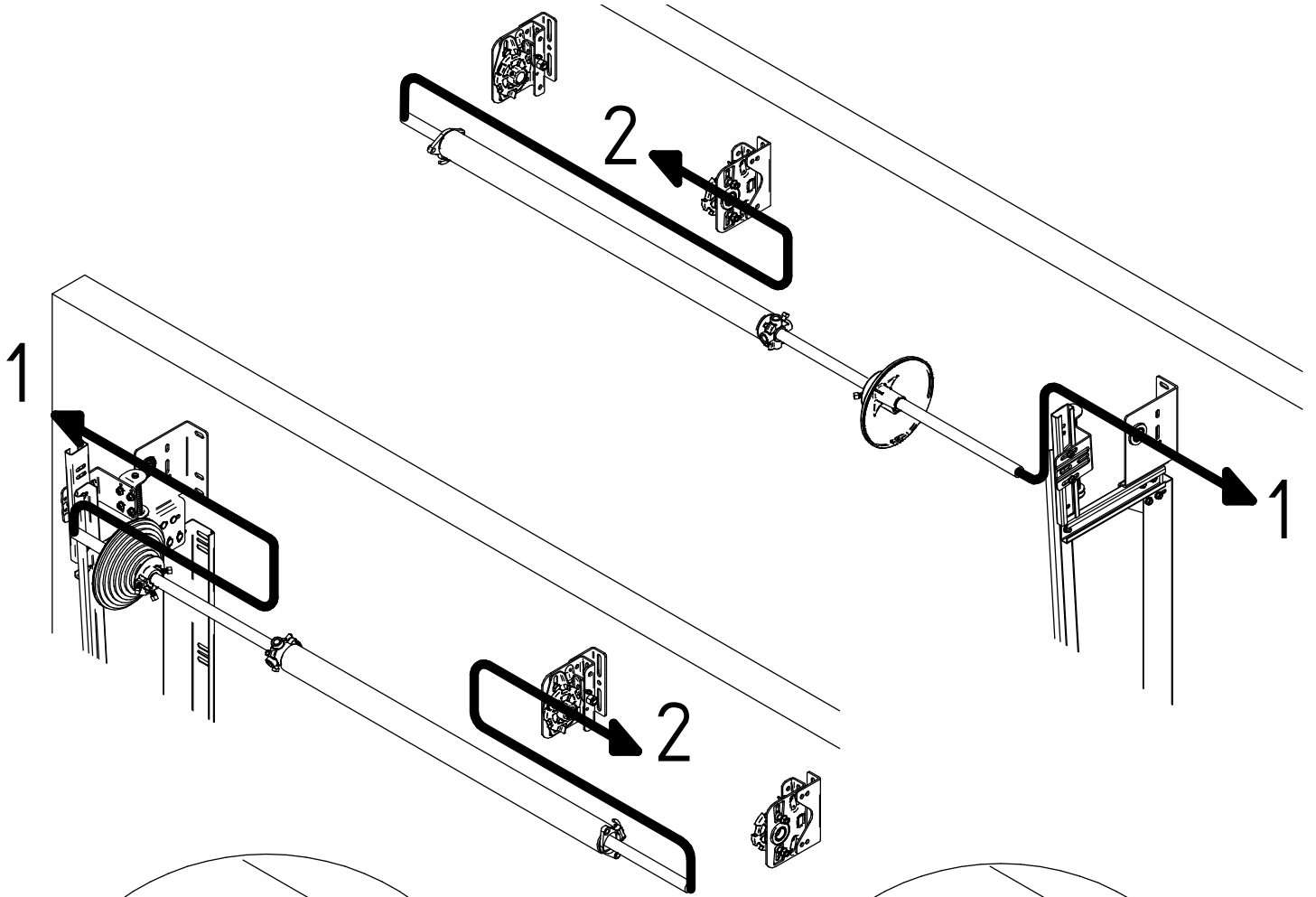

1

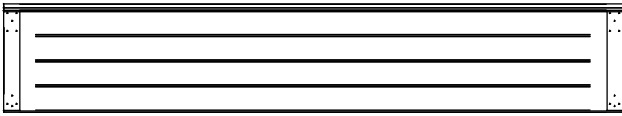

2



3

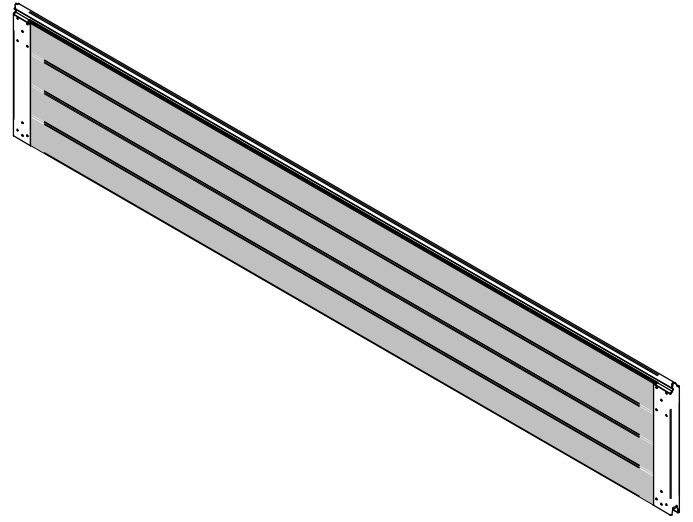
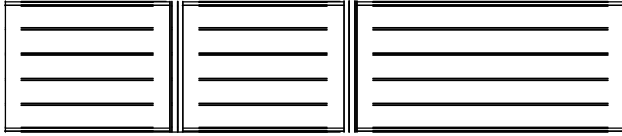

1

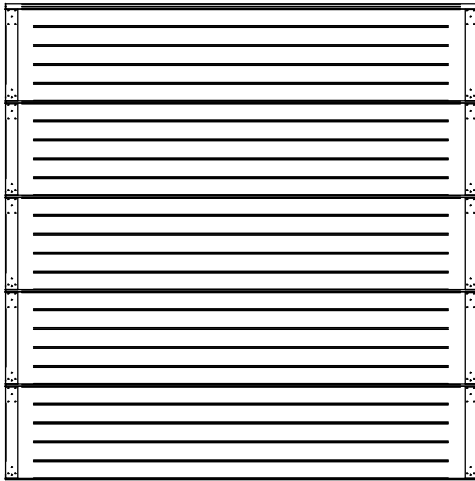

3

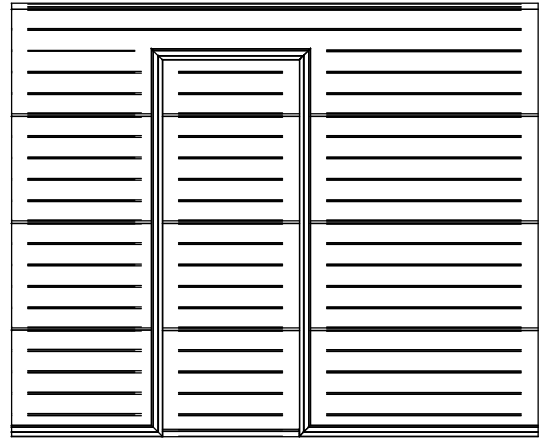

2

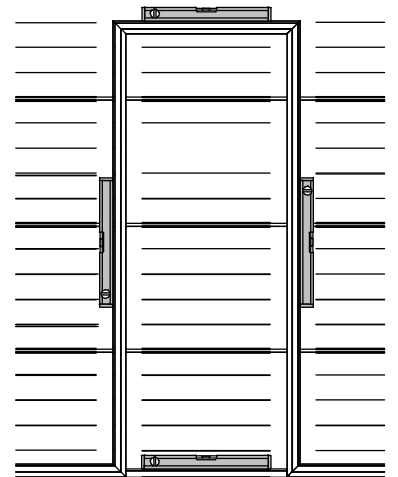
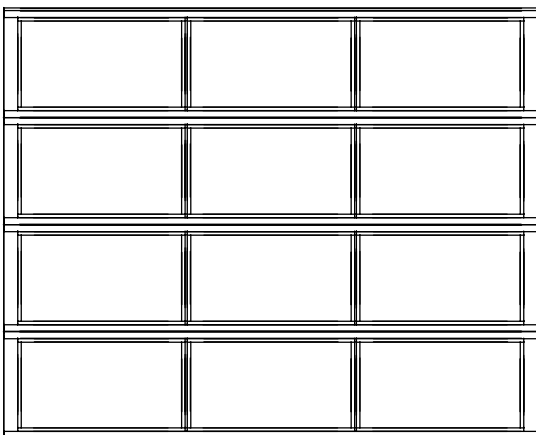

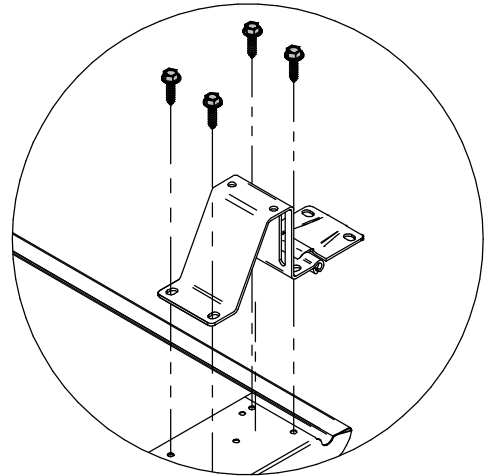
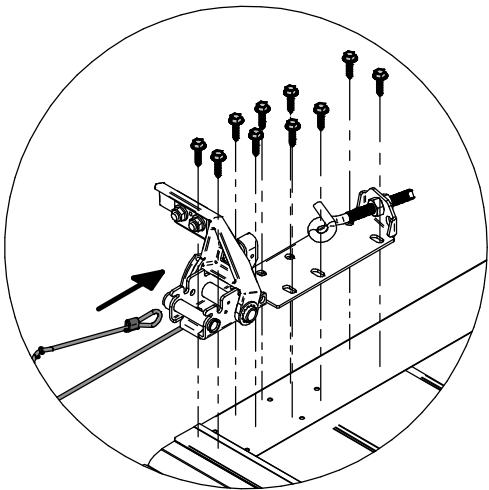
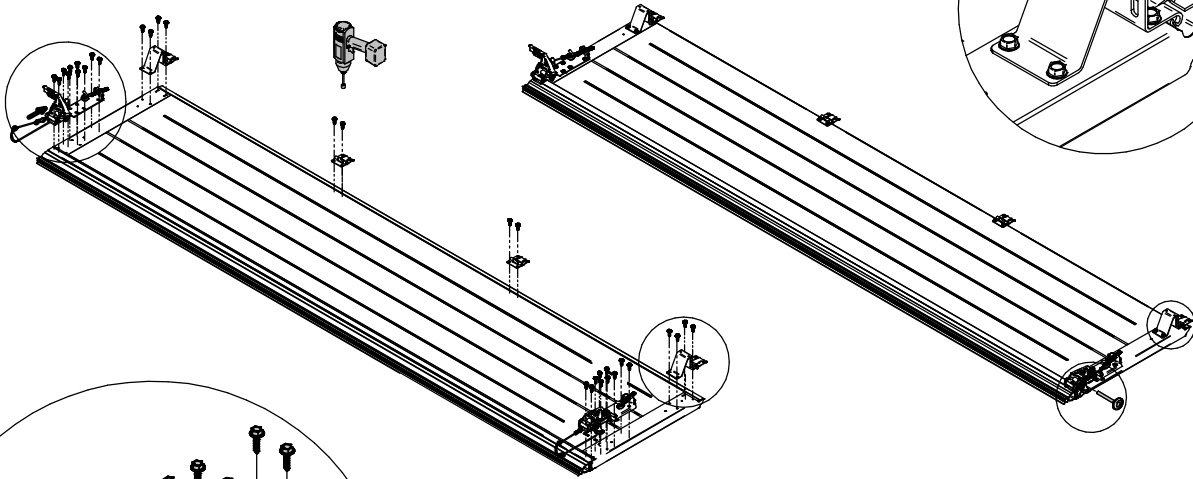
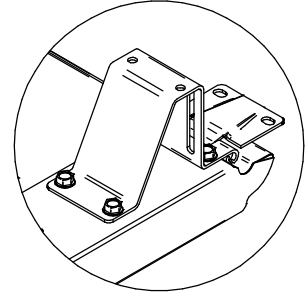
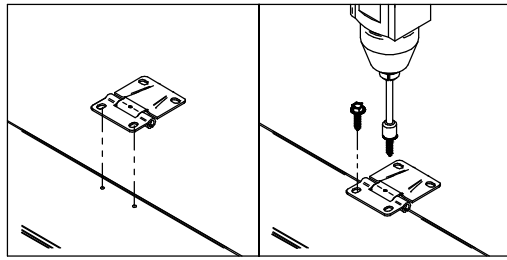
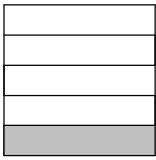

Alternativ:

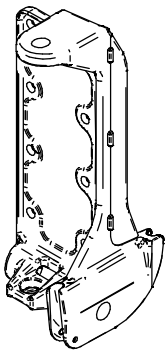

3170

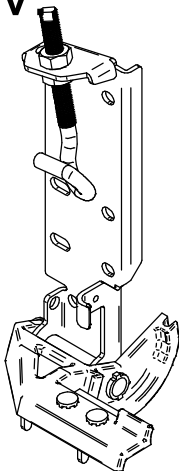

3172-3173

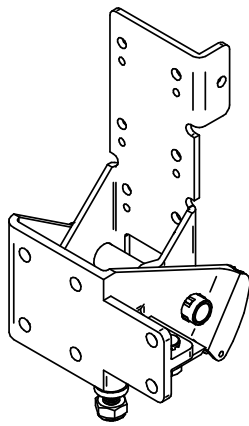

3194

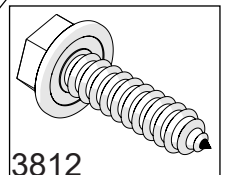
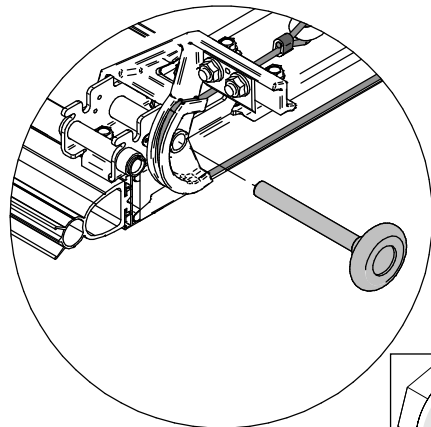

3812

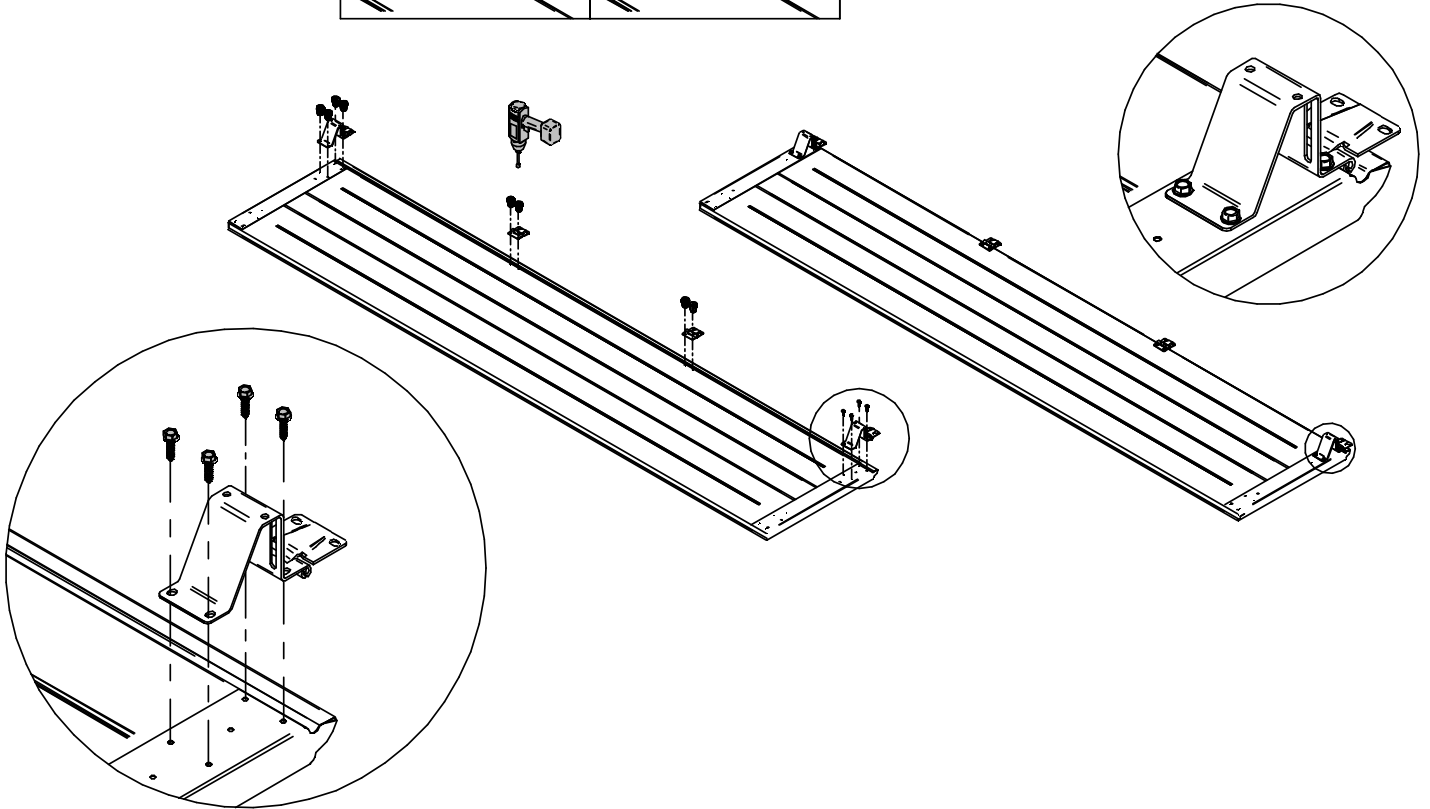
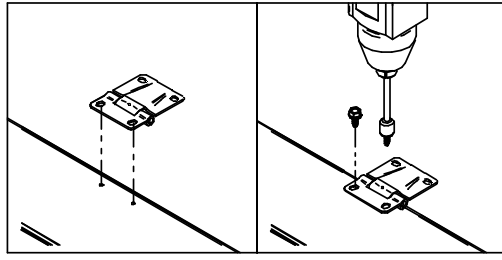
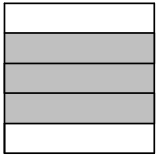

DMB \geq 5000 mm

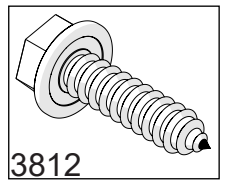
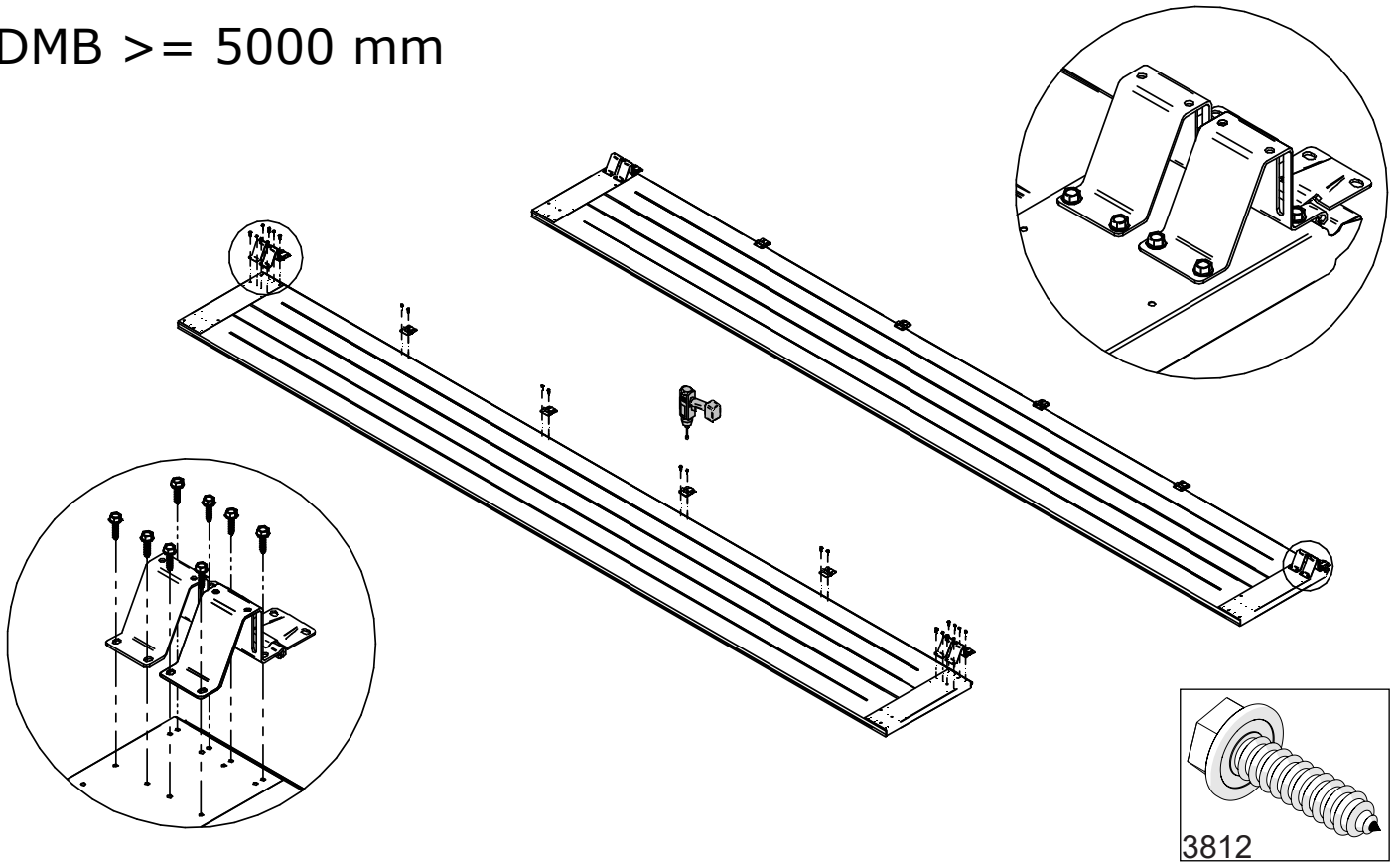

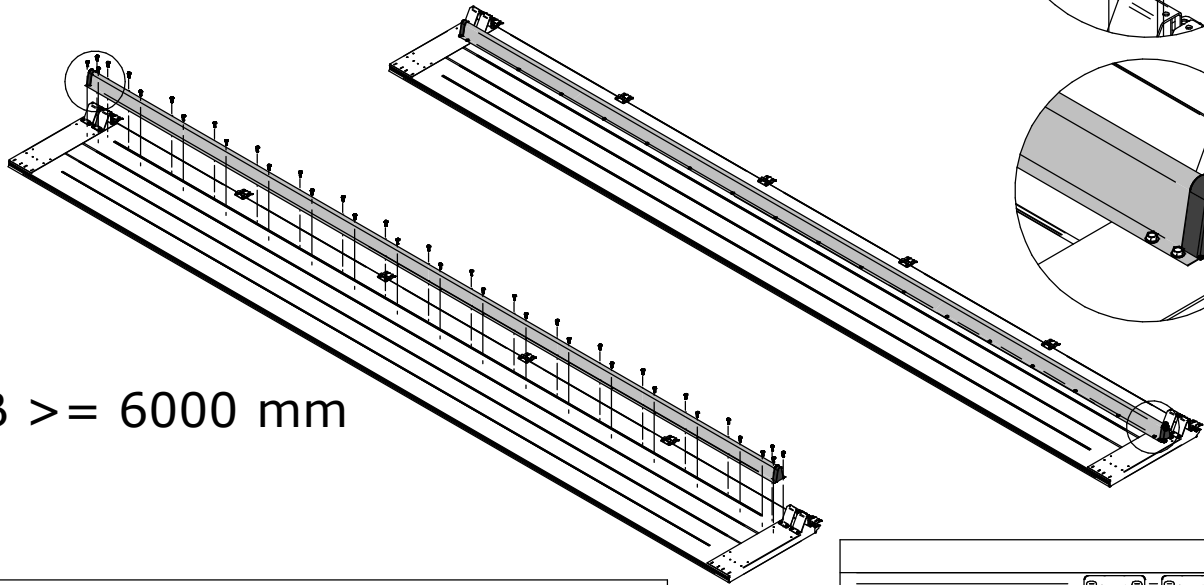
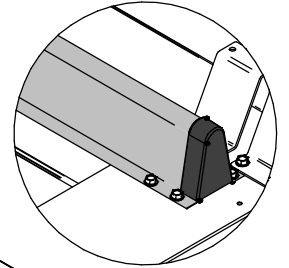
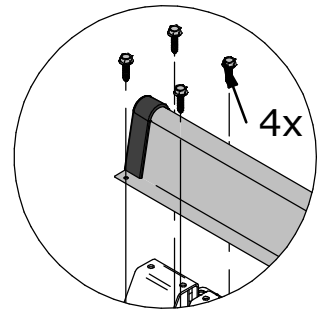
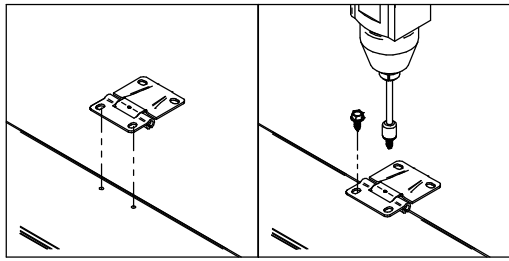
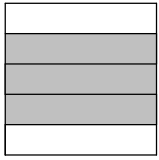

DMB \geq 6000 mm

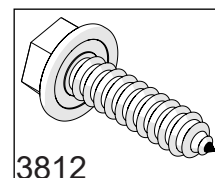
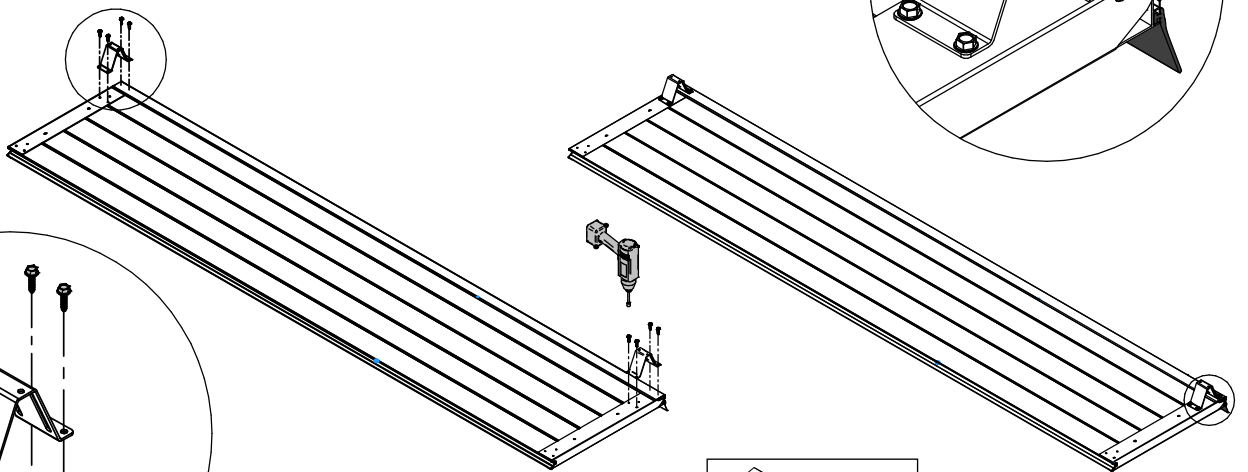
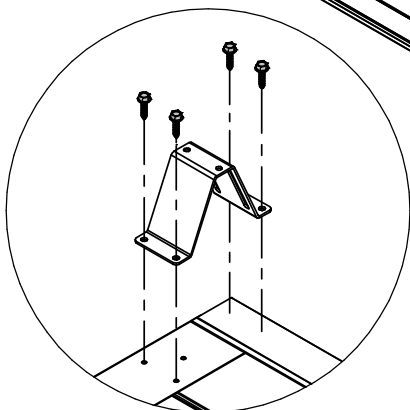
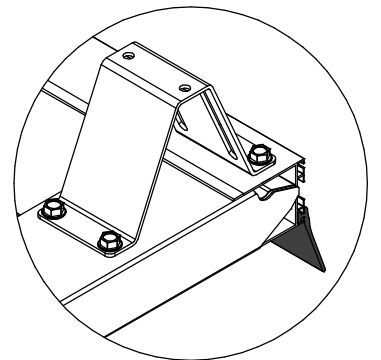
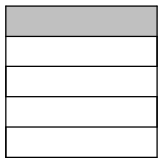
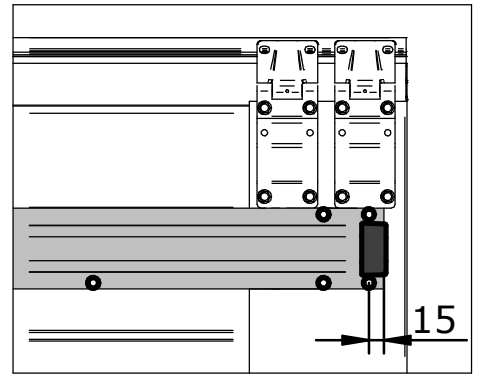
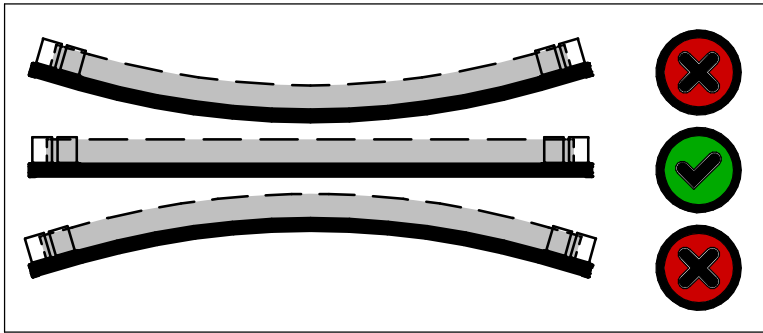

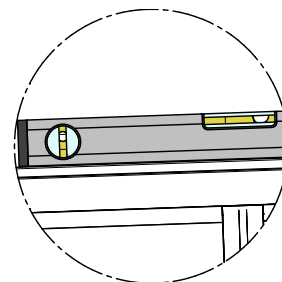
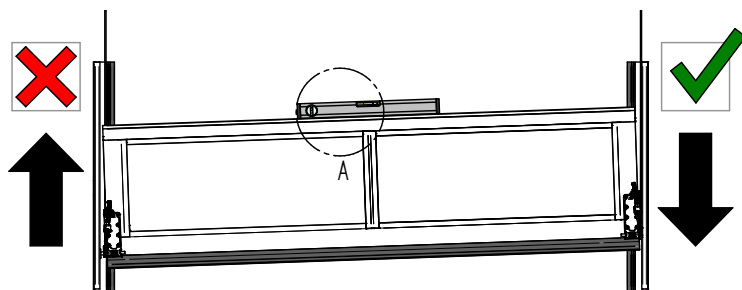
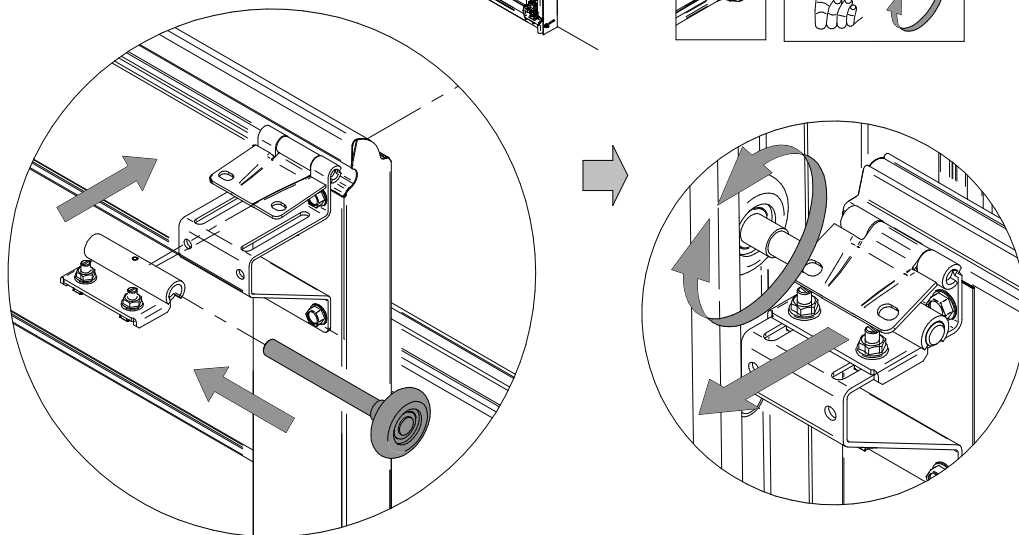
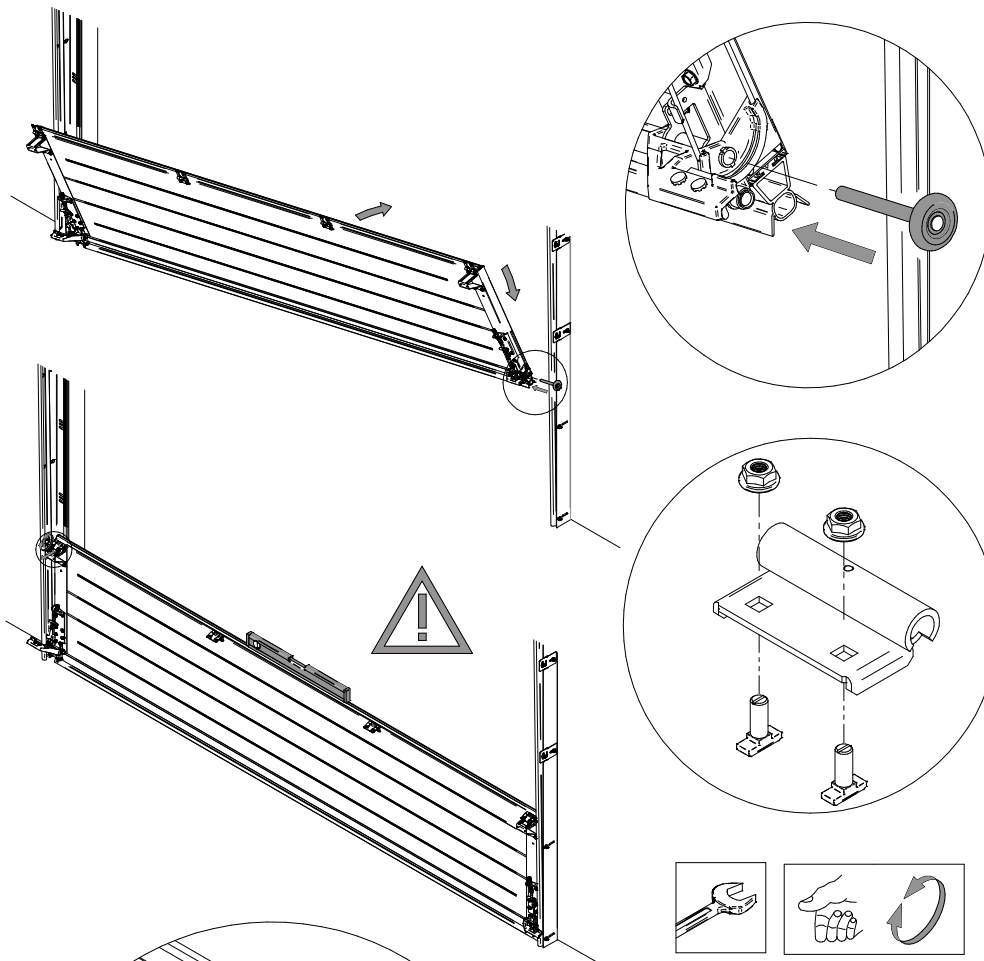

DETALJ A

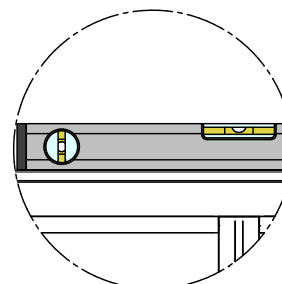
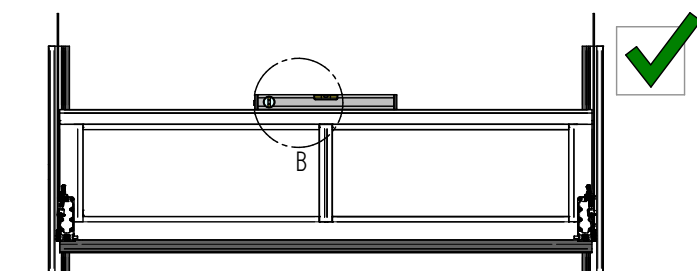

DETALJ B

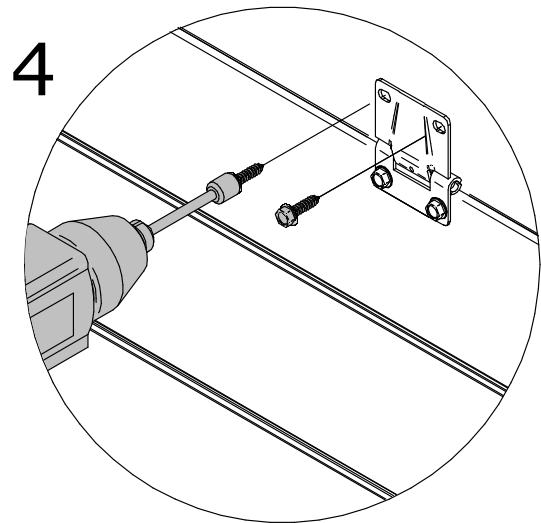
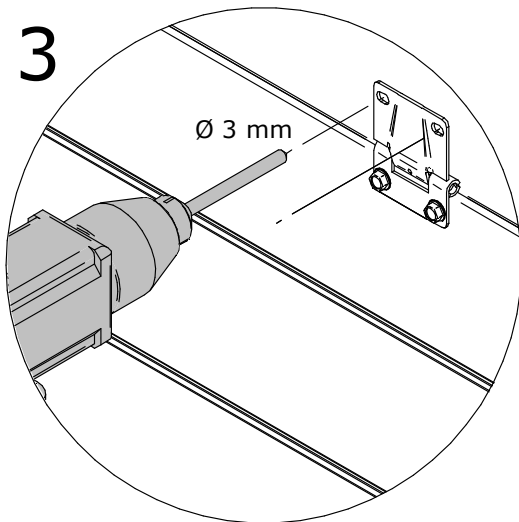
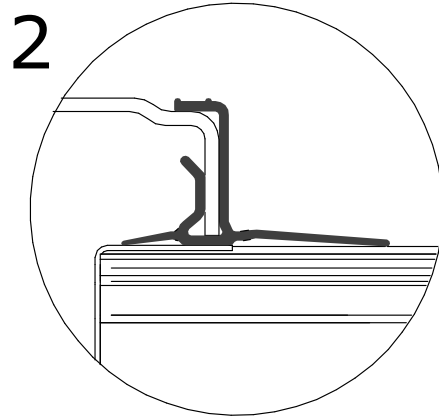
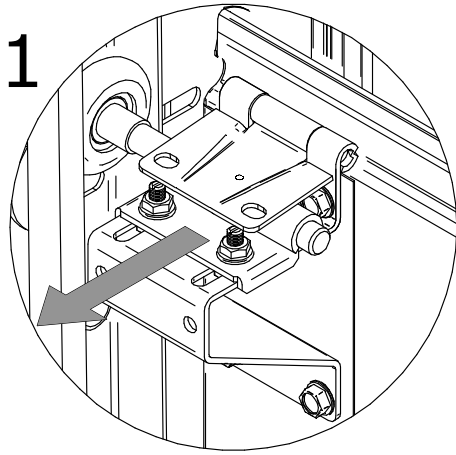
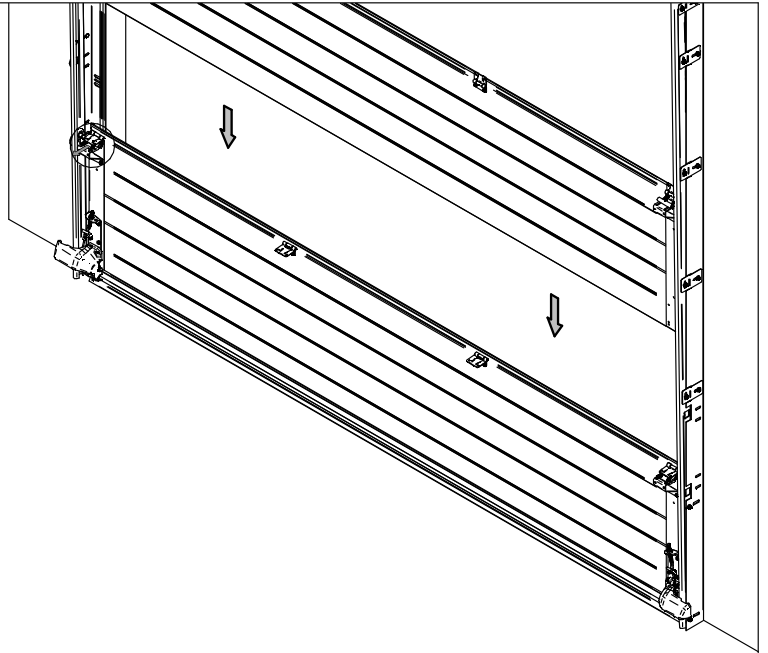
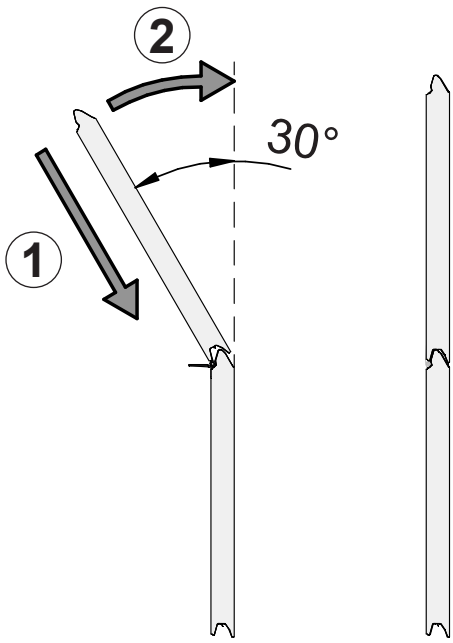

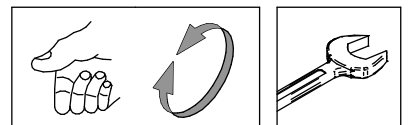
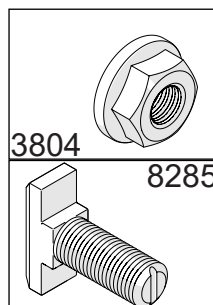
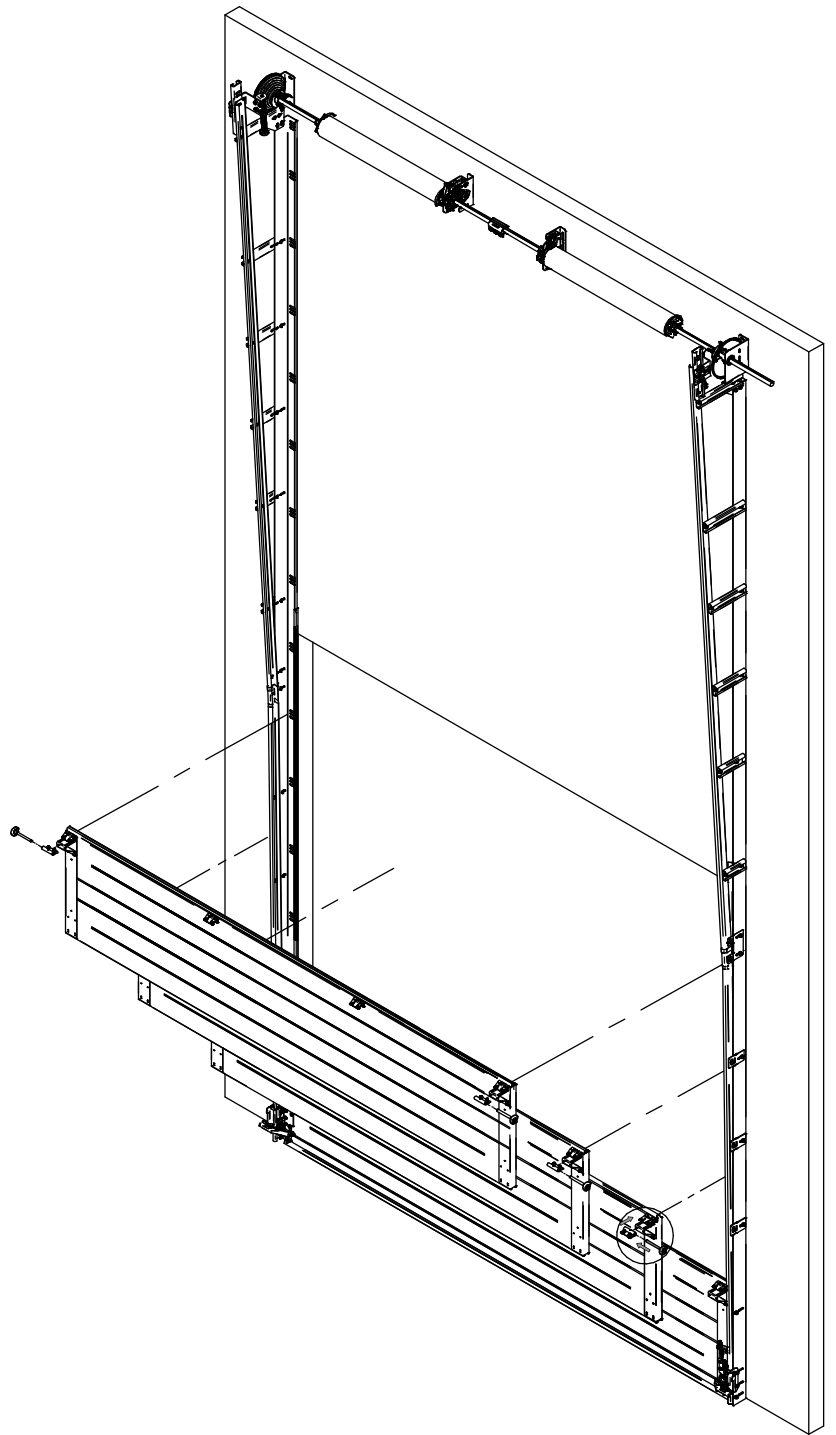
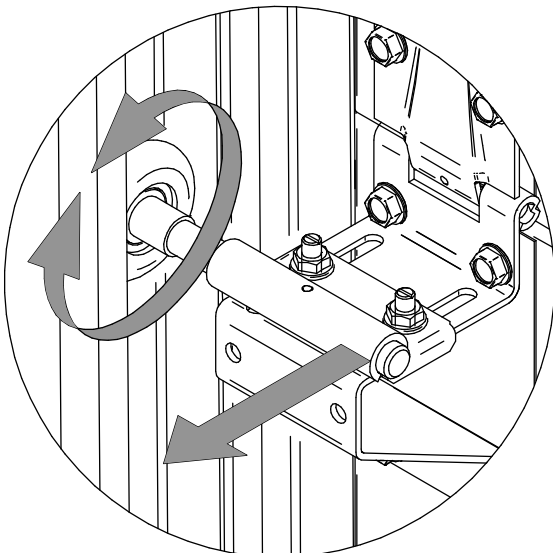
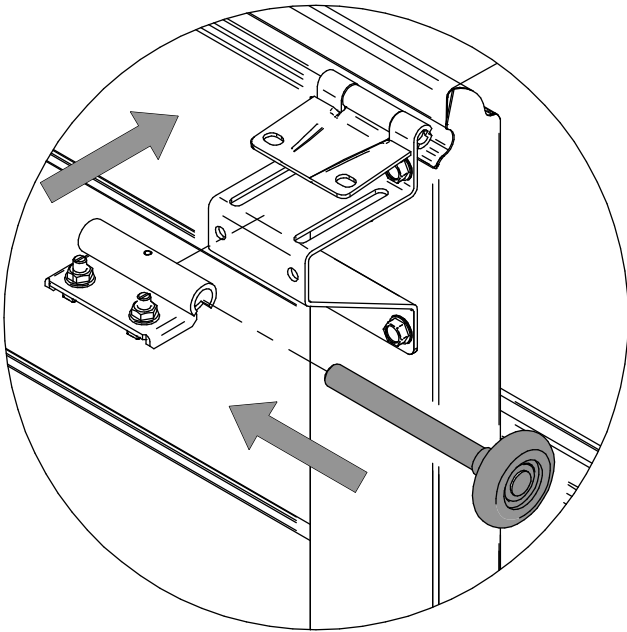
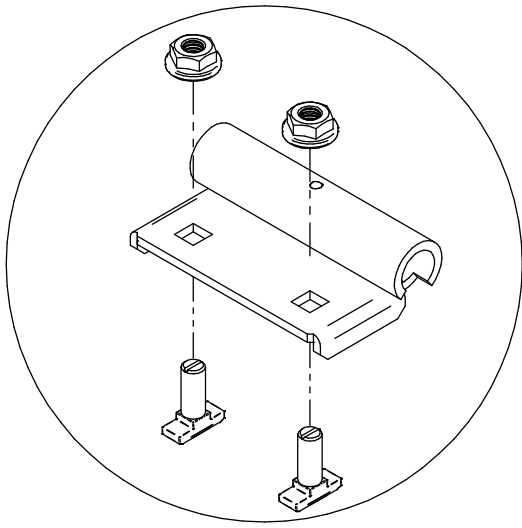

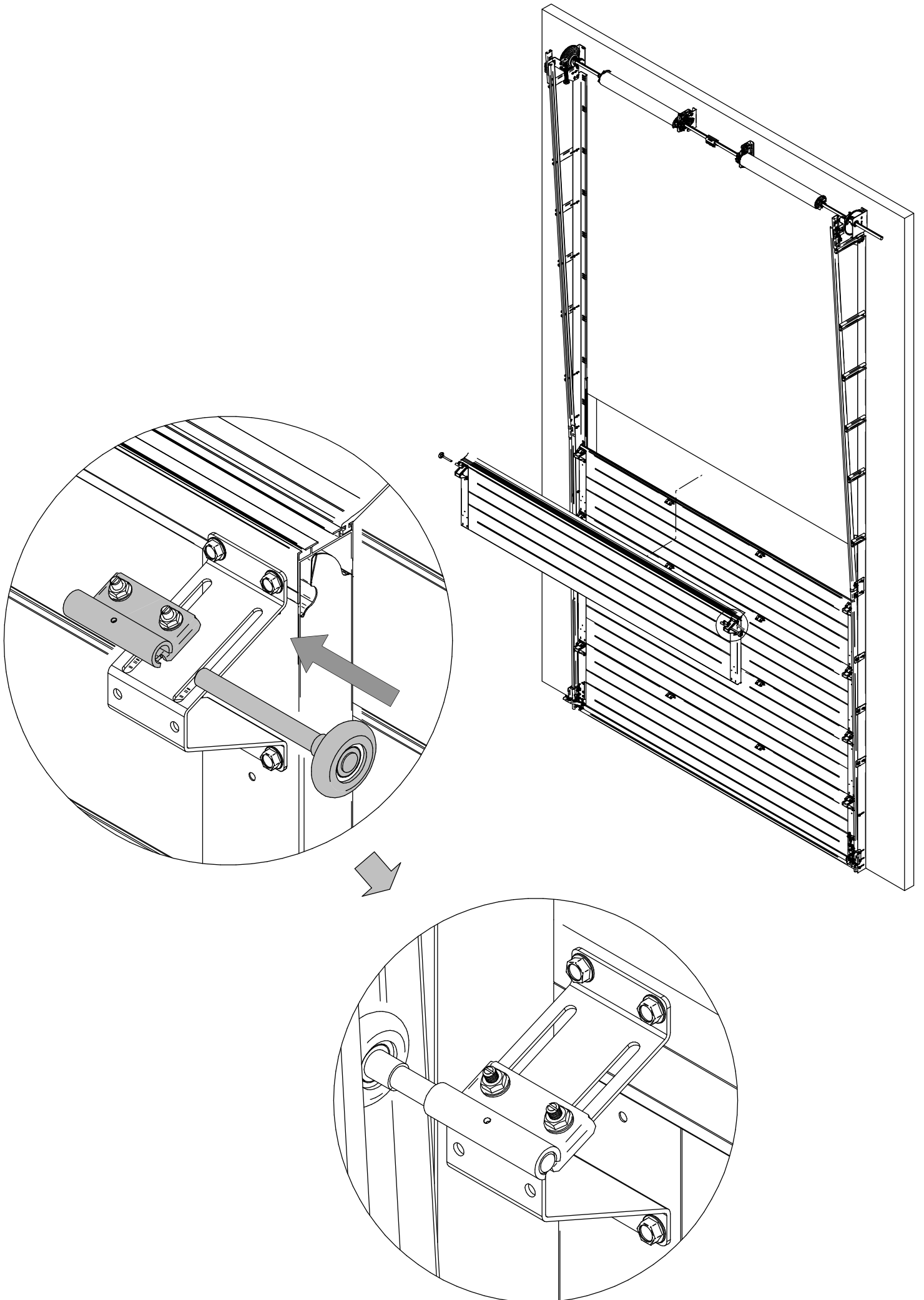

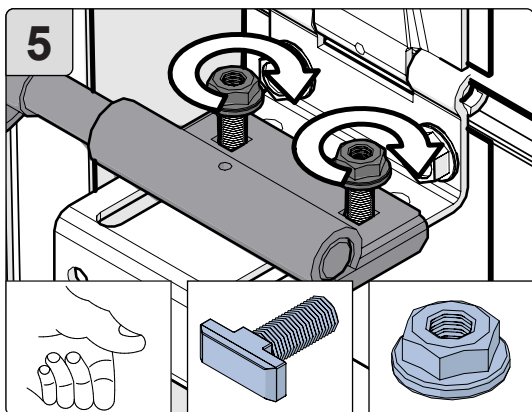
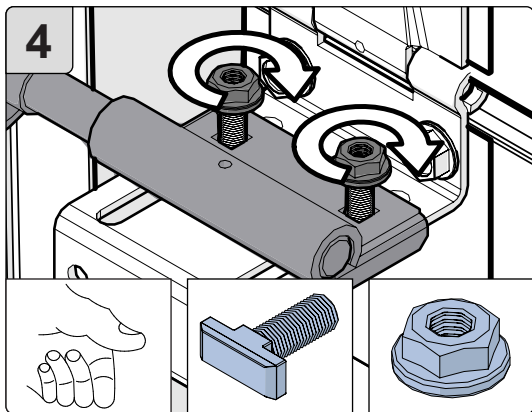
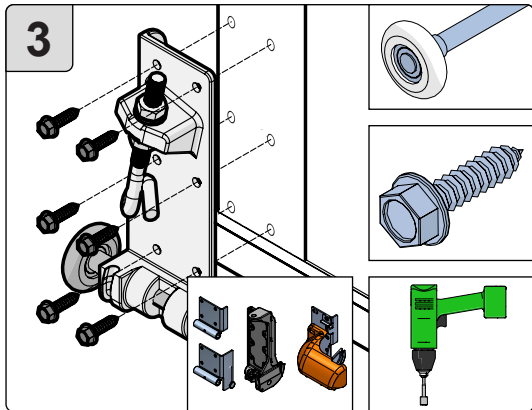
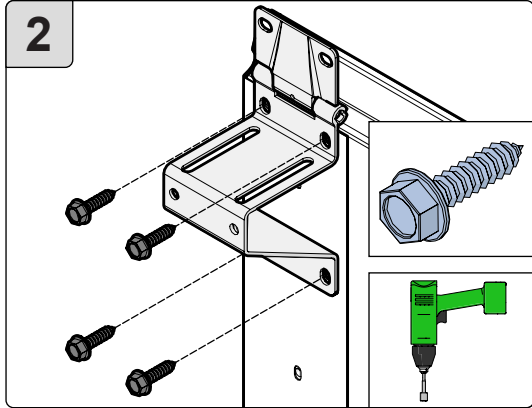
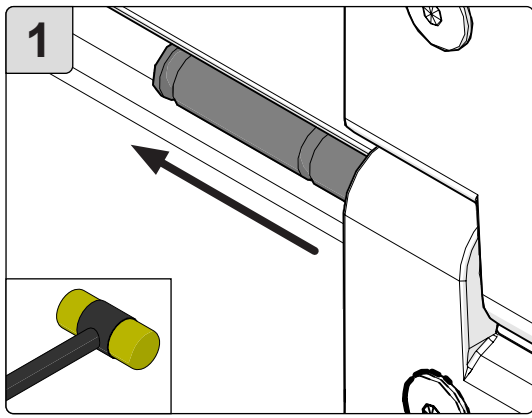

ALTERNATIV

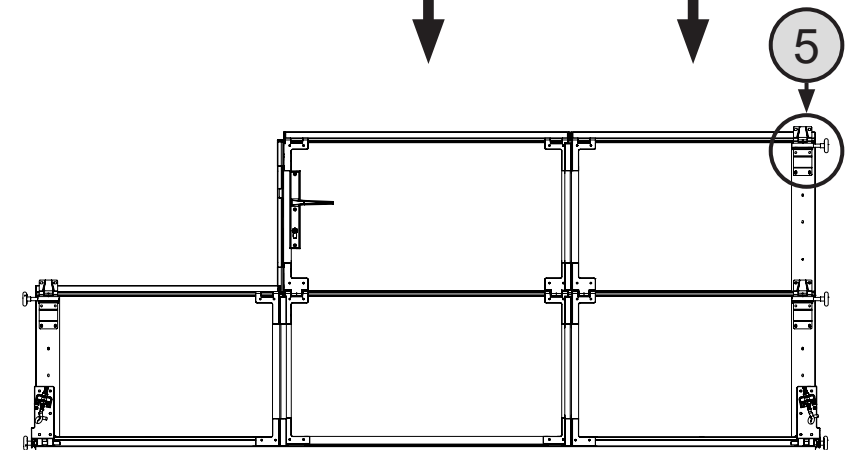
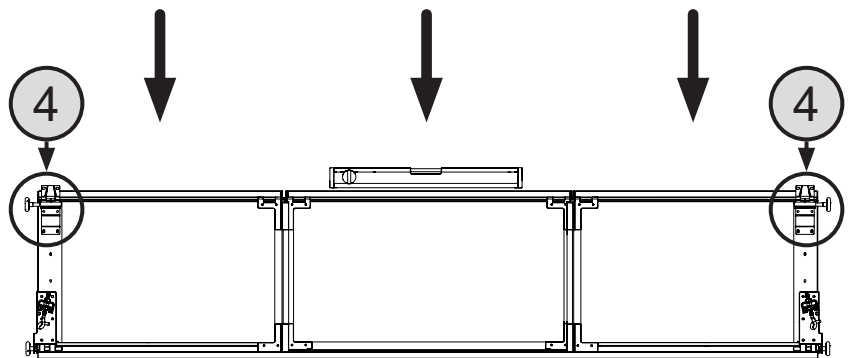
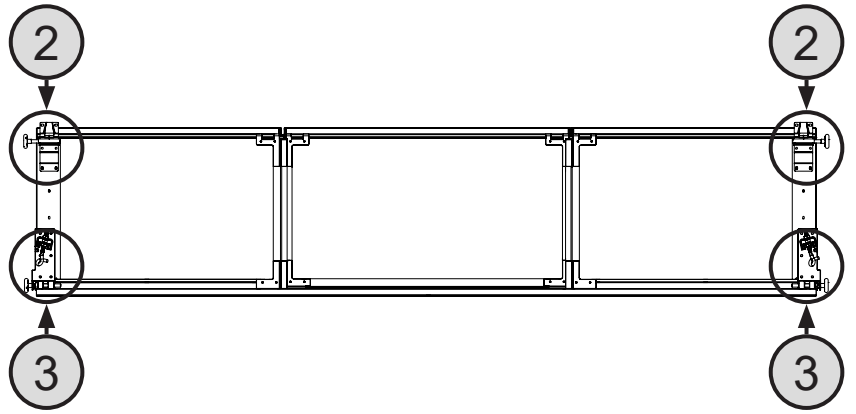

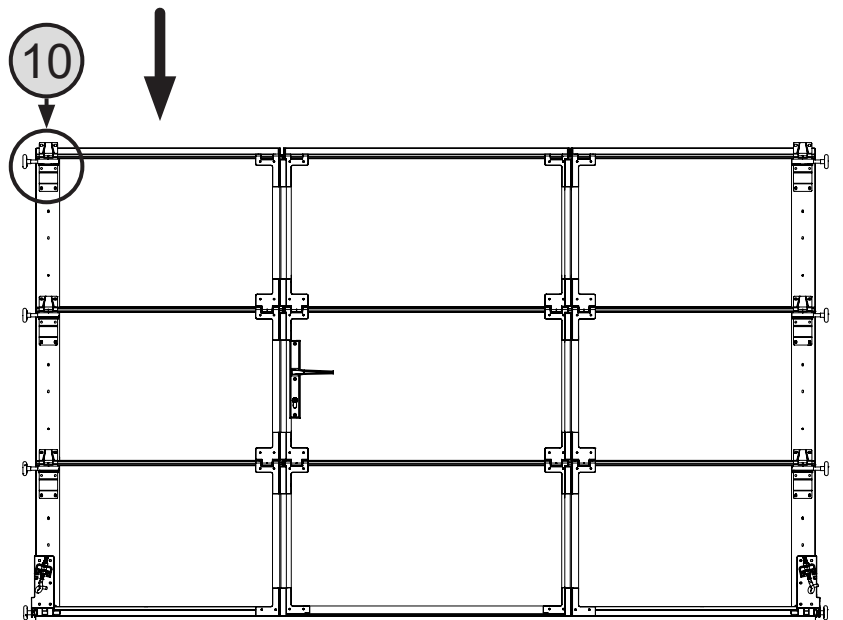
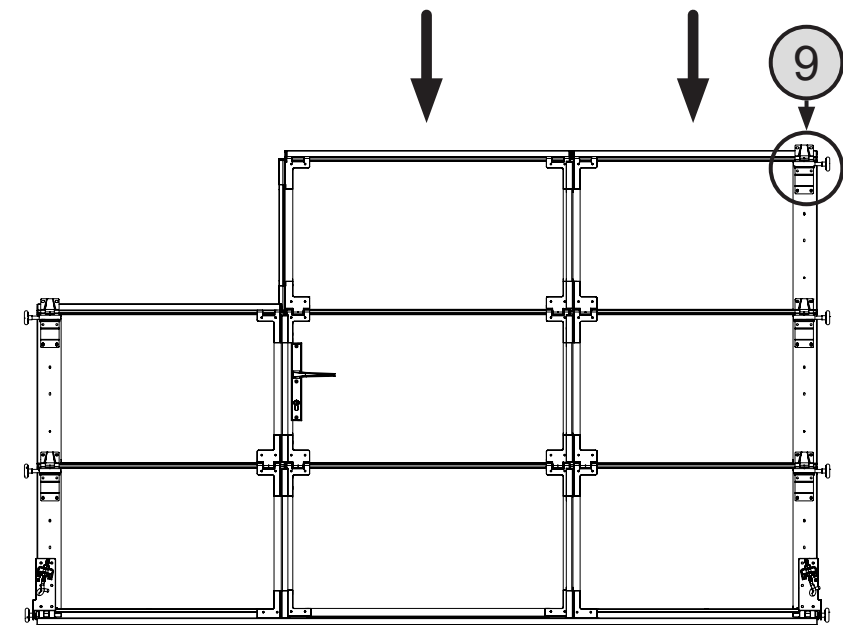
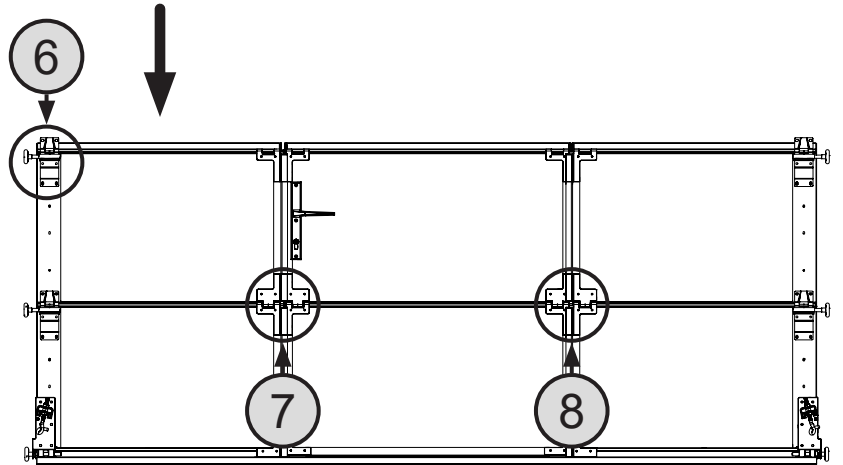
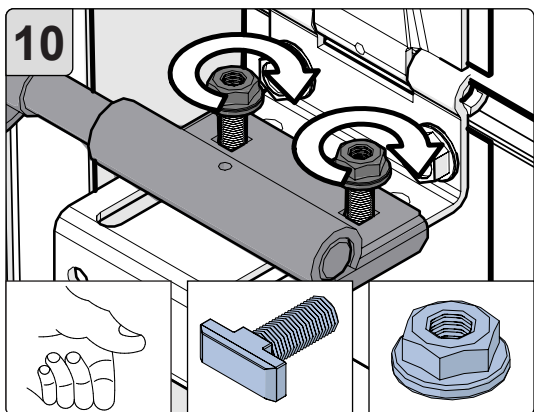
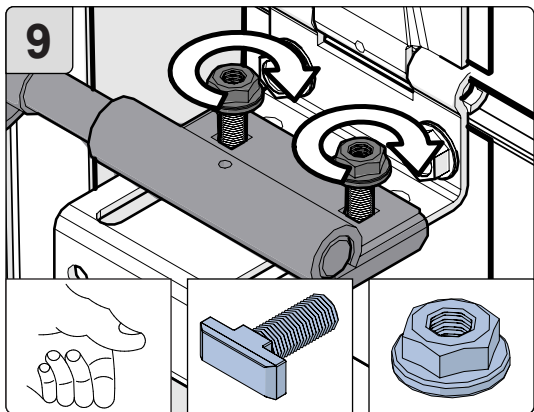
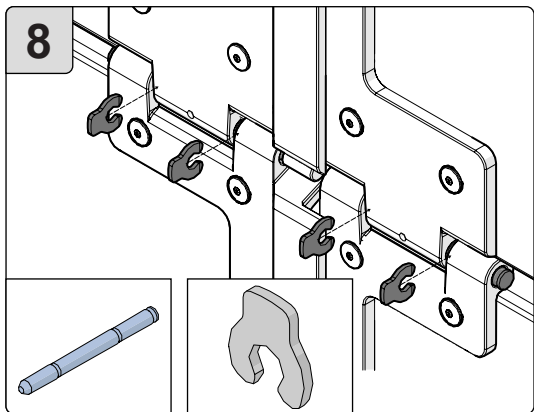
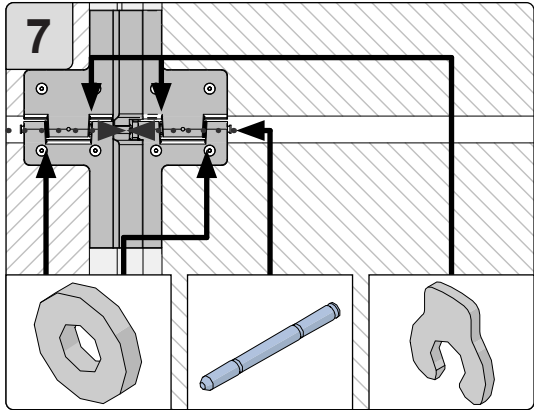
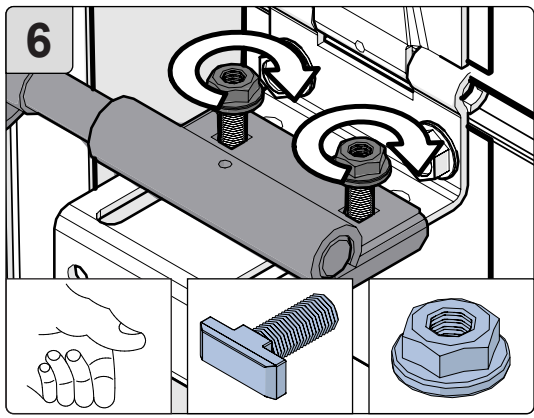

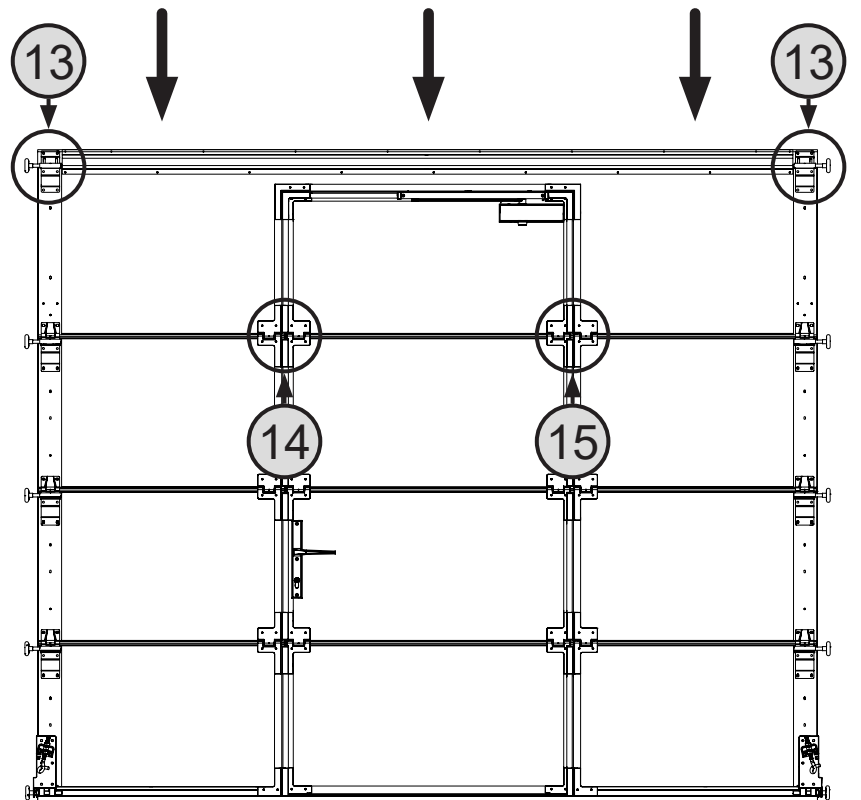
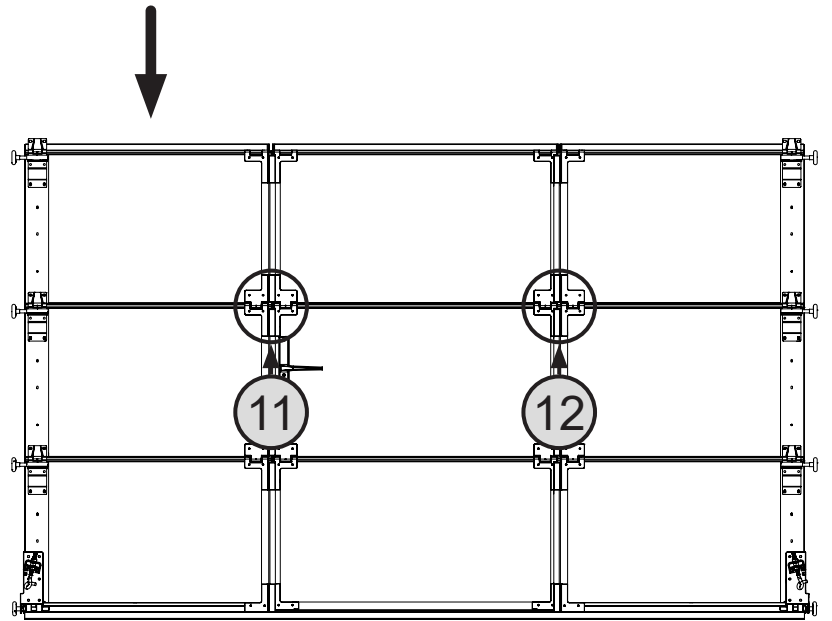
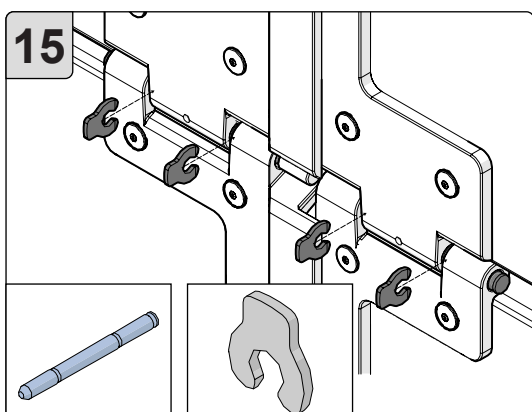
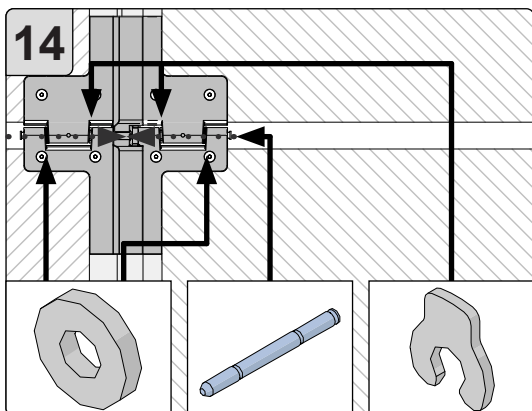
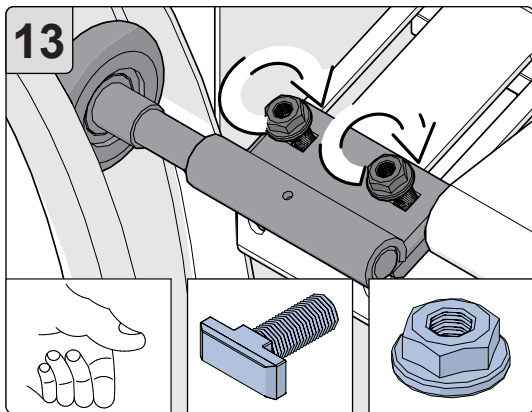
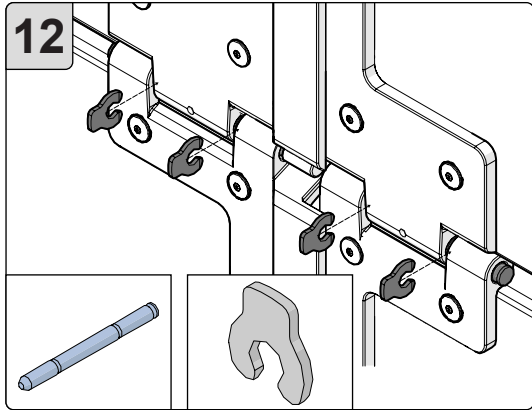
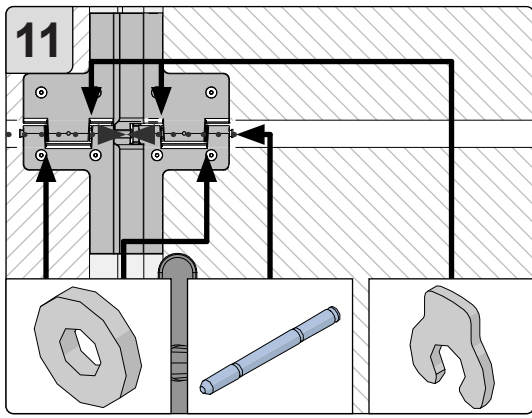

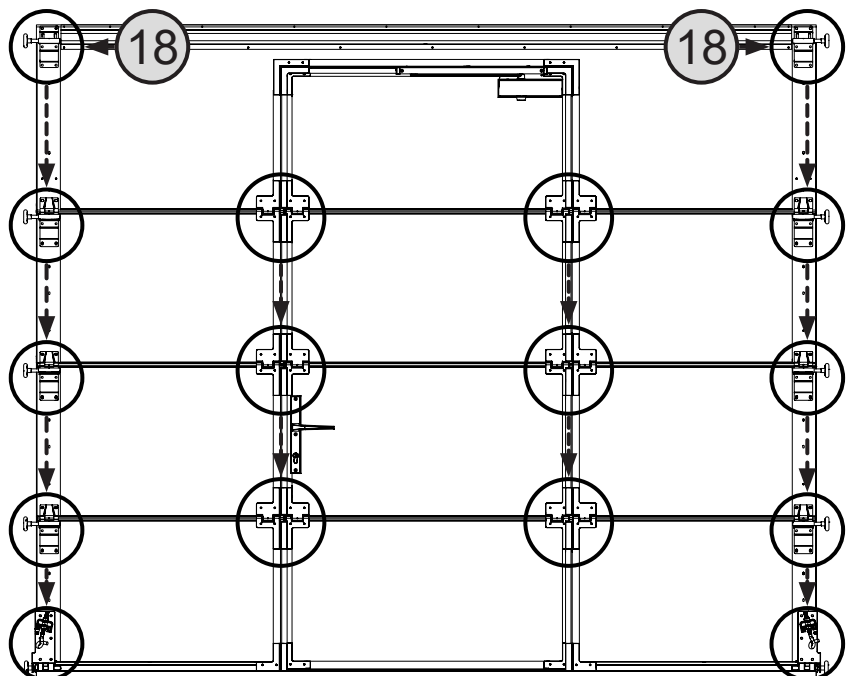
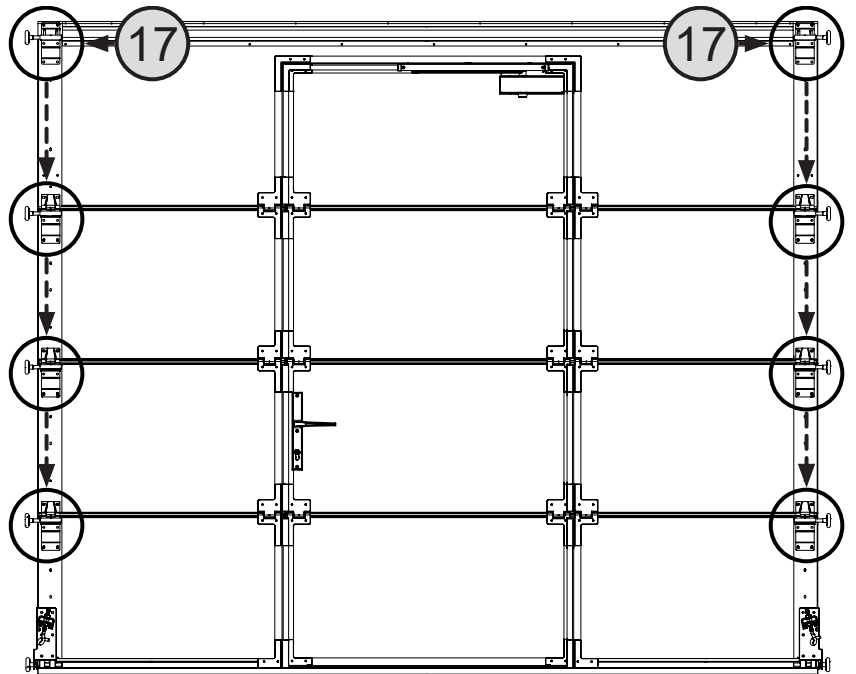
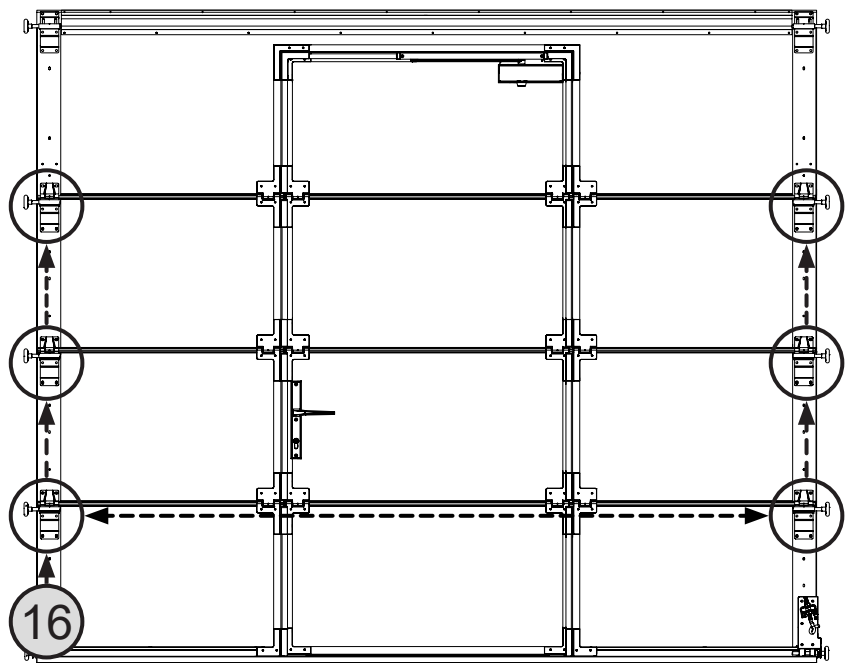
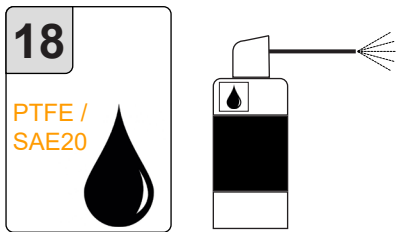
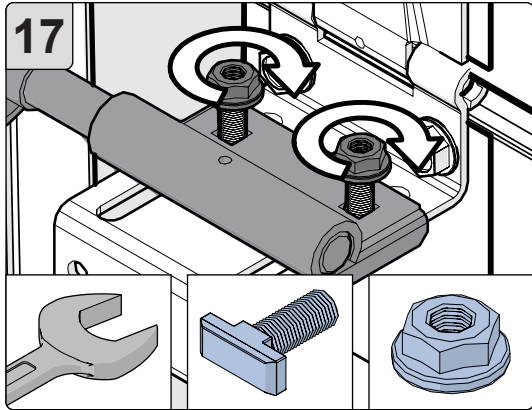
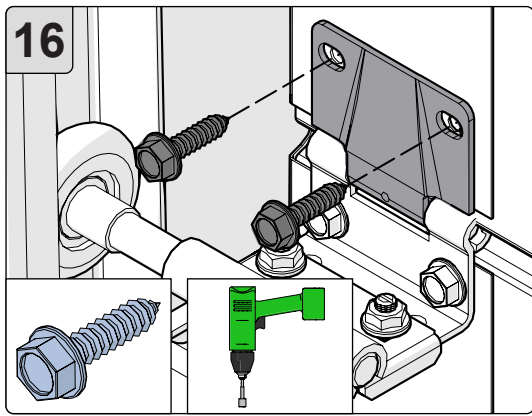

Alternativ

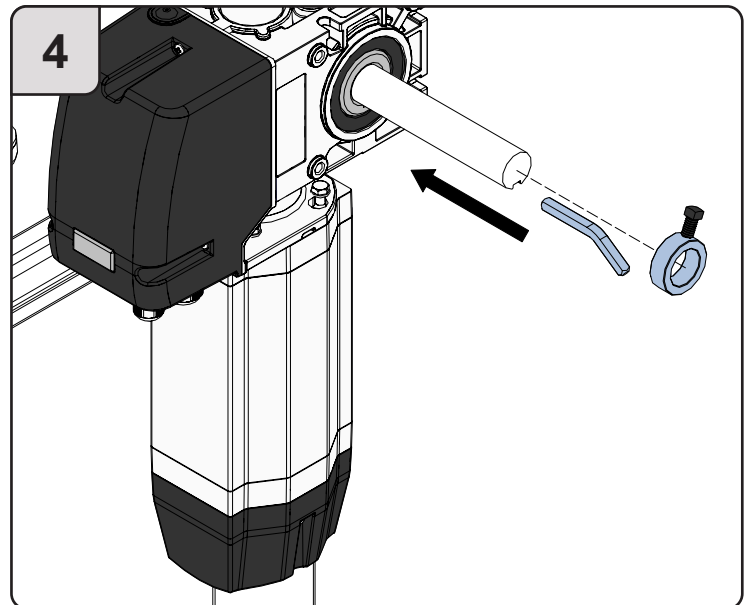
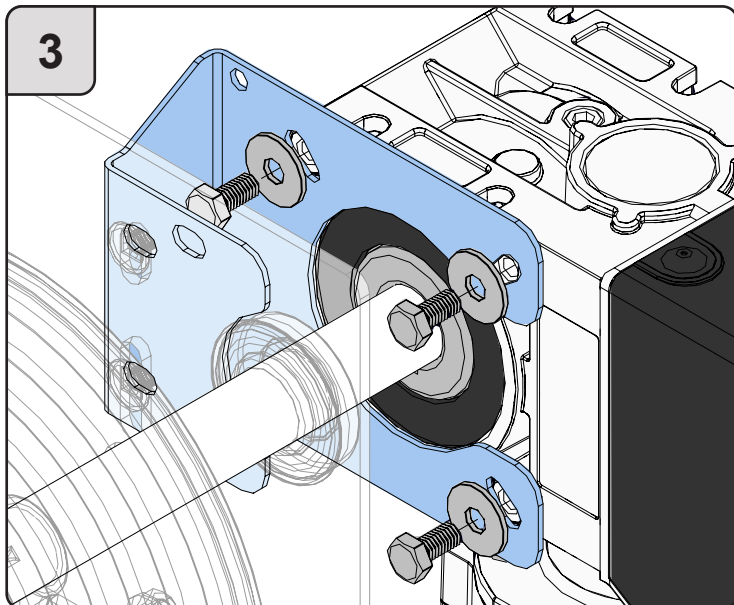
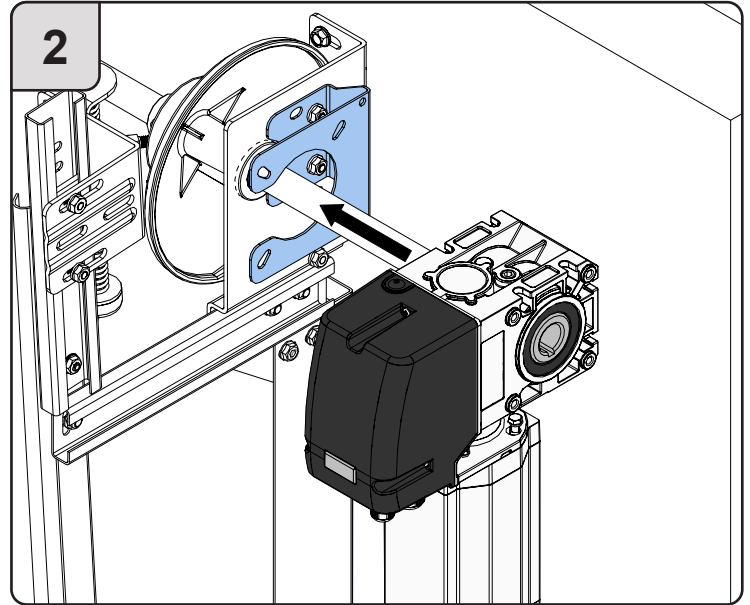
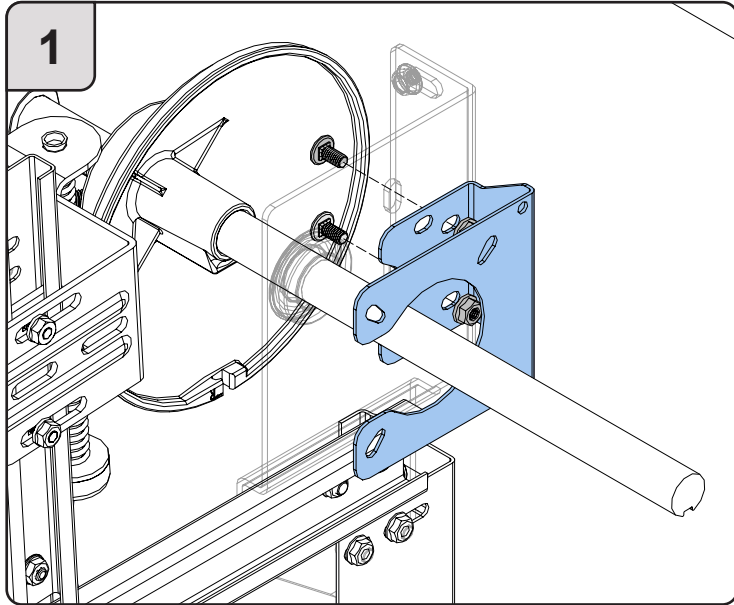

Alternativ

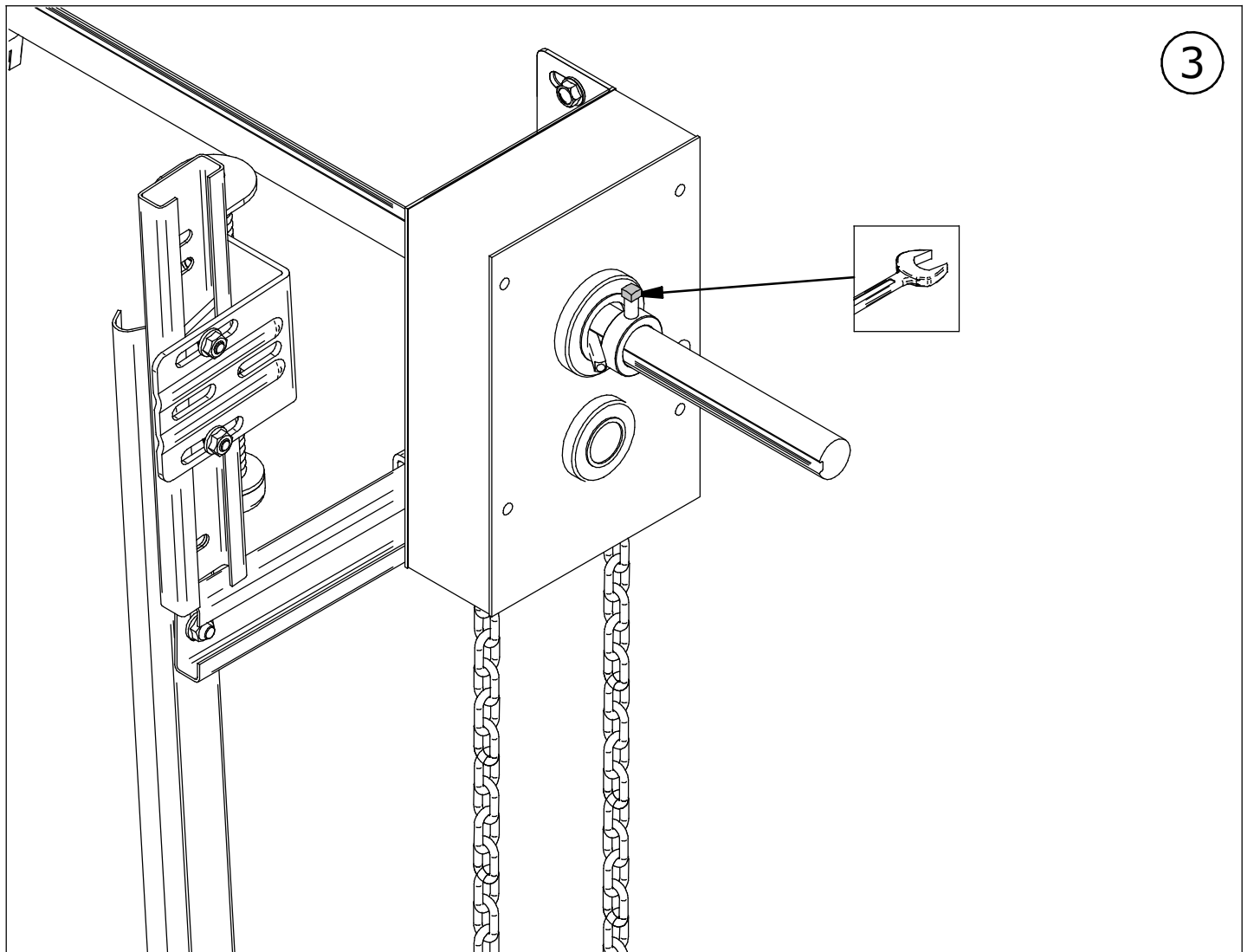
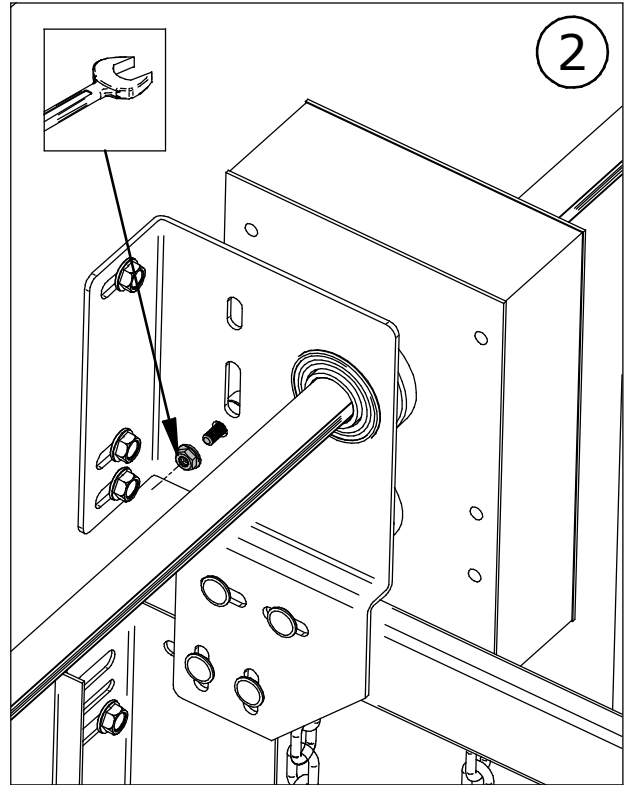
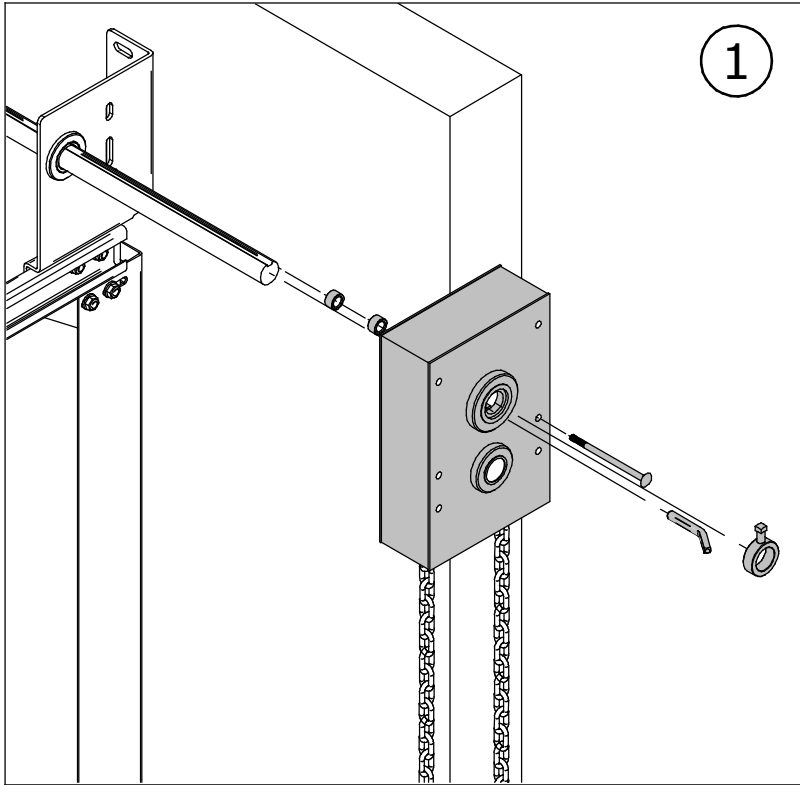

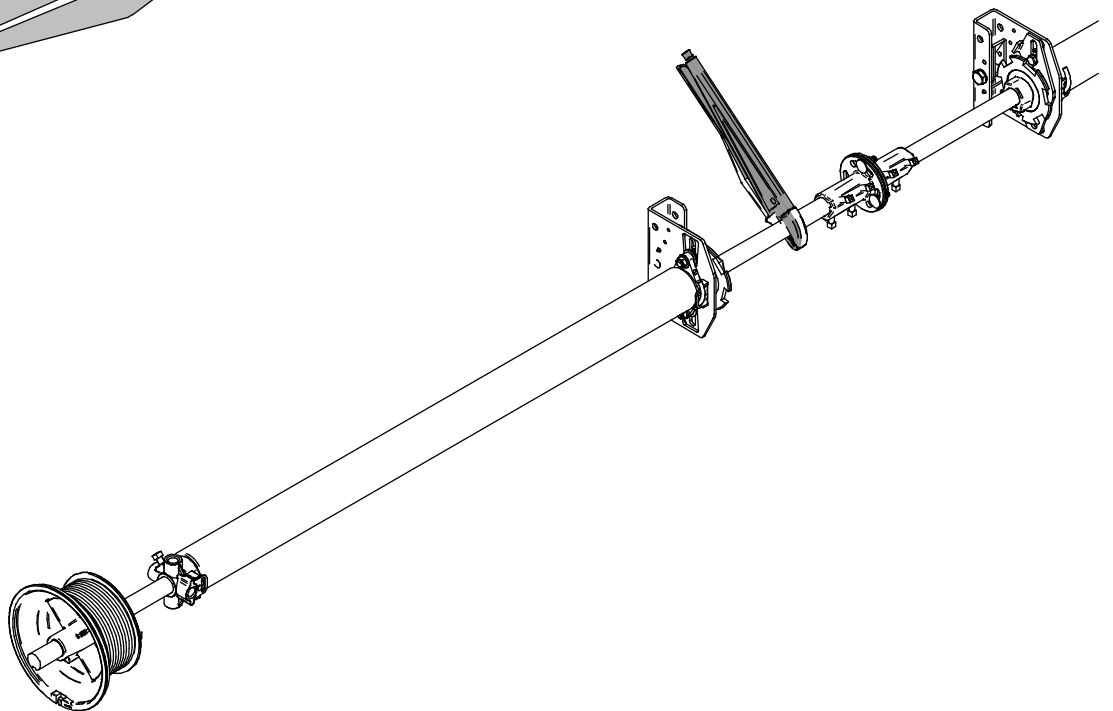
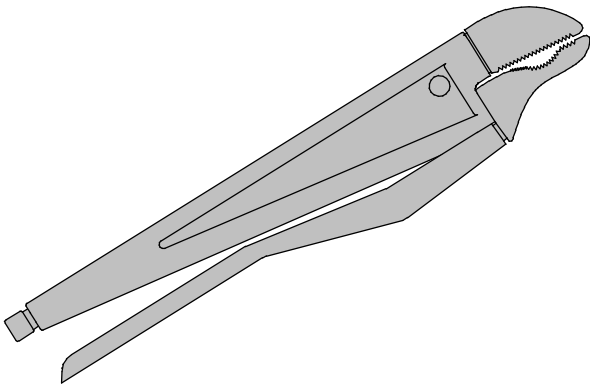
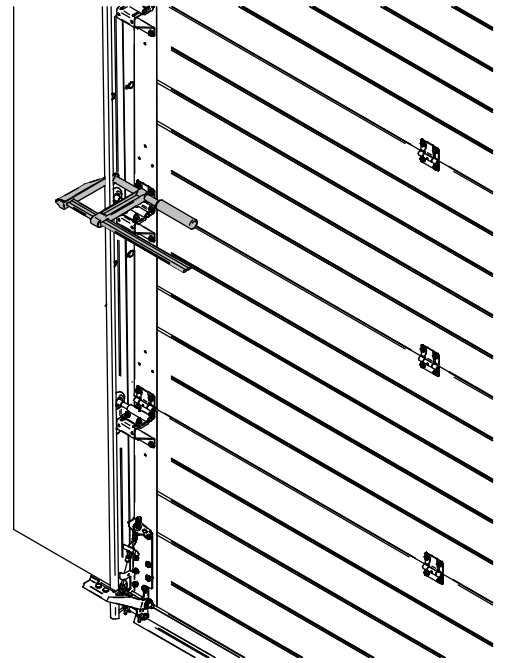
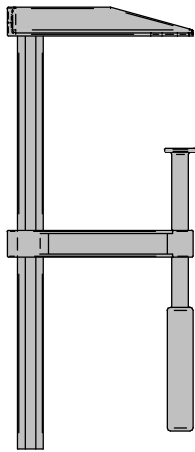

1

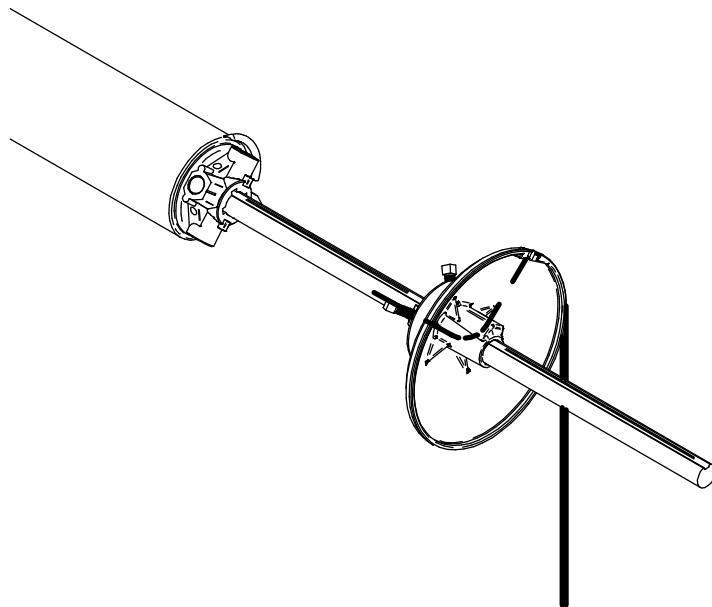
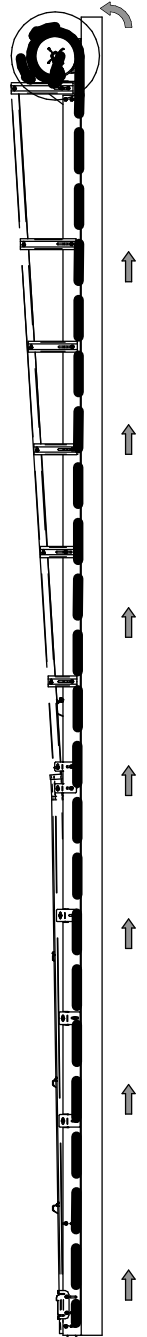
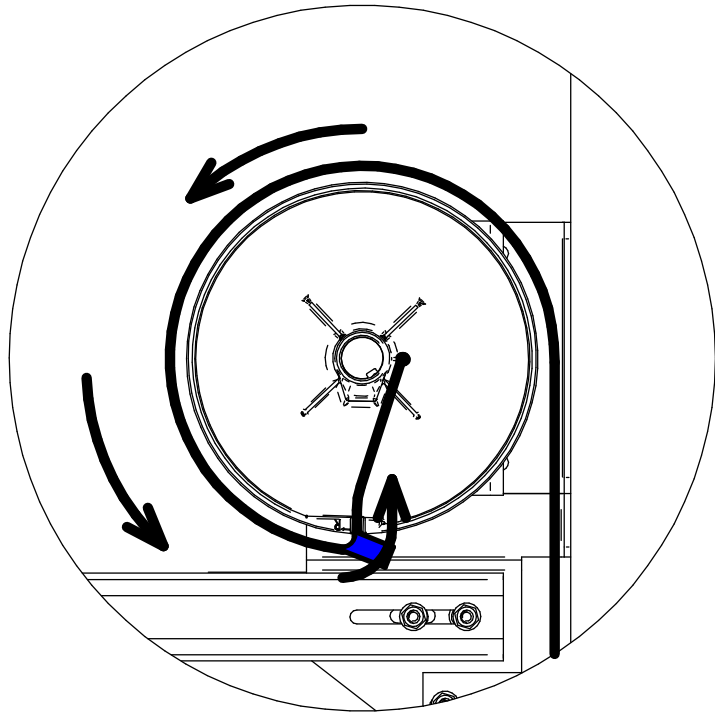
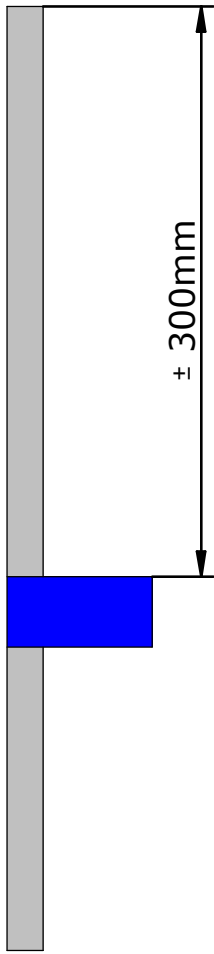

2

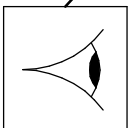
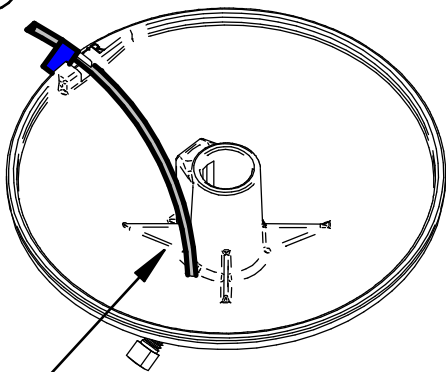

3

- $\frac{1}{2}$ x Säkerhetsvarv
- $\frac{1}{2}$ x Sicherheitswicklung
- $\frac{1}{2}$ x Safety wind
- $\frac{1}{2}$ x Tour de sécurité

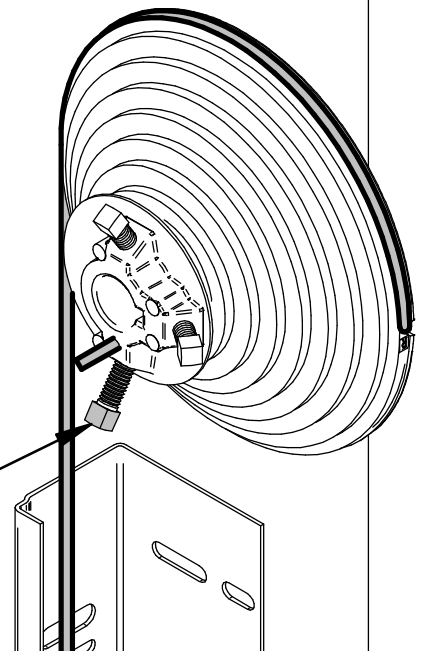
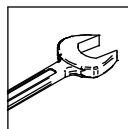

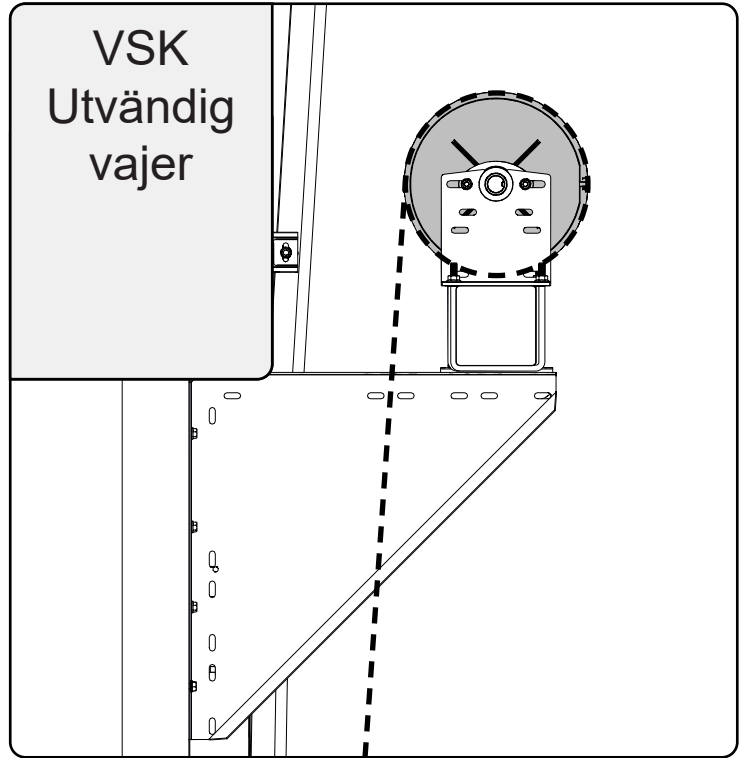
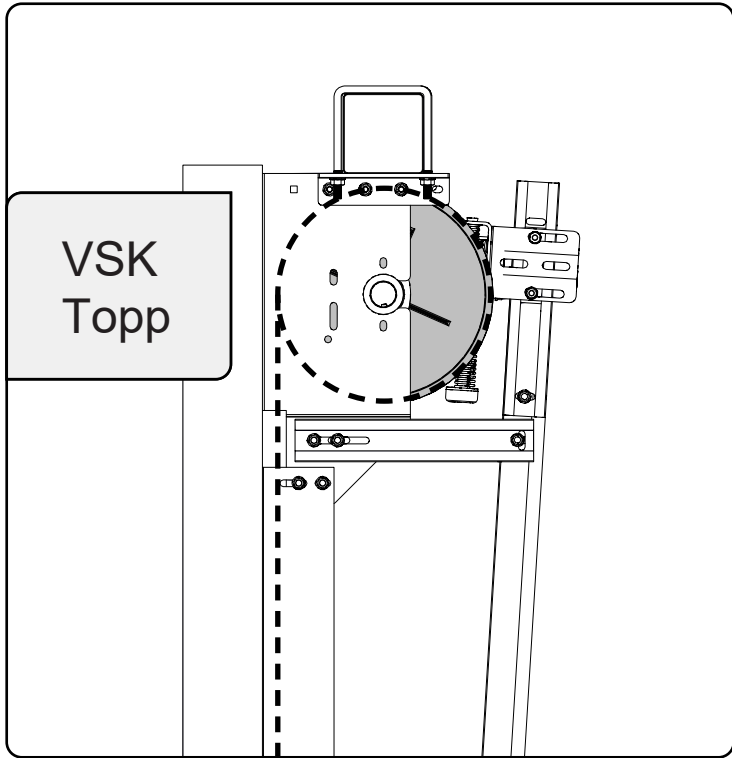
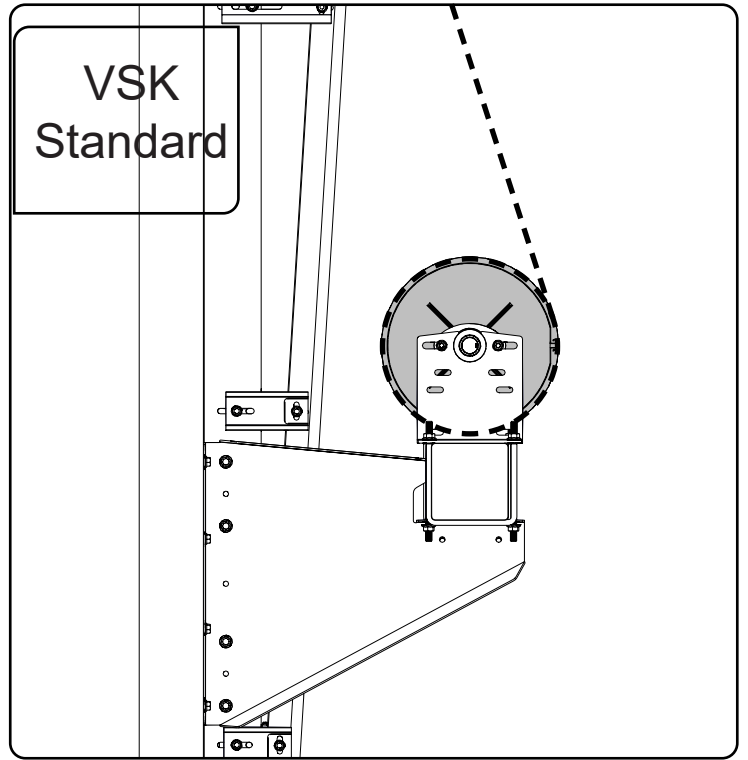
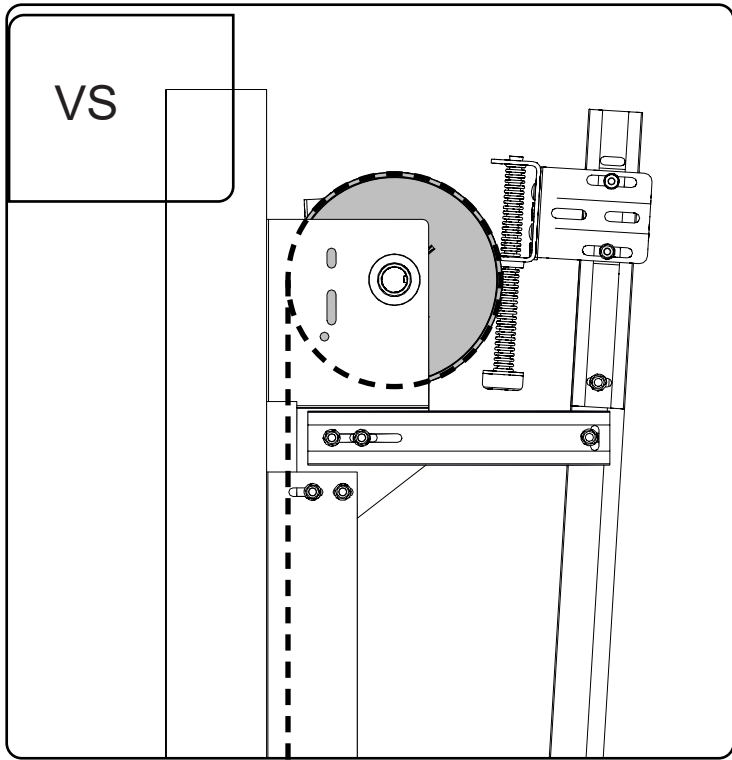

Varv x 360°

PW 12 Bon Hardware Industrie

Pitch Hilift

E

Aant Deurtype DMB DMH Secties Velden Beslag Gewicht Turns

0 0

Klant

Klant

referentie:

Transport

11.4

Aant	Eenheid	Art. nr.	Artikel omschrijving	Doos	Lengte	Verpakt / Controle
1	-		Springs Left 6,00x51x950 Powdercoated			<input type="checkbox"/> <input type="checkbox"/>
1	-		Springs Right 6,00x51x950 Powdercoated			<input type="checkbox"/> <input type="checkbox"/>



FJÄDERSPÄNNARE för fjäderdiameter < 152 mm

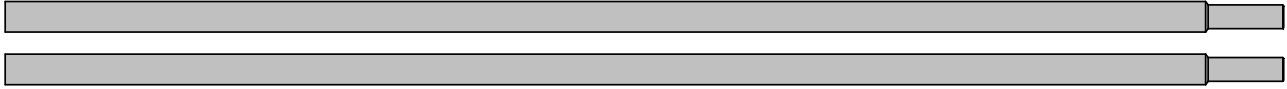

FJÄDERSPÄNNARE för fjäderdiameter < 67 mm

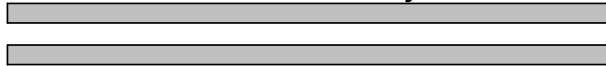

HÄRDAT STÅL

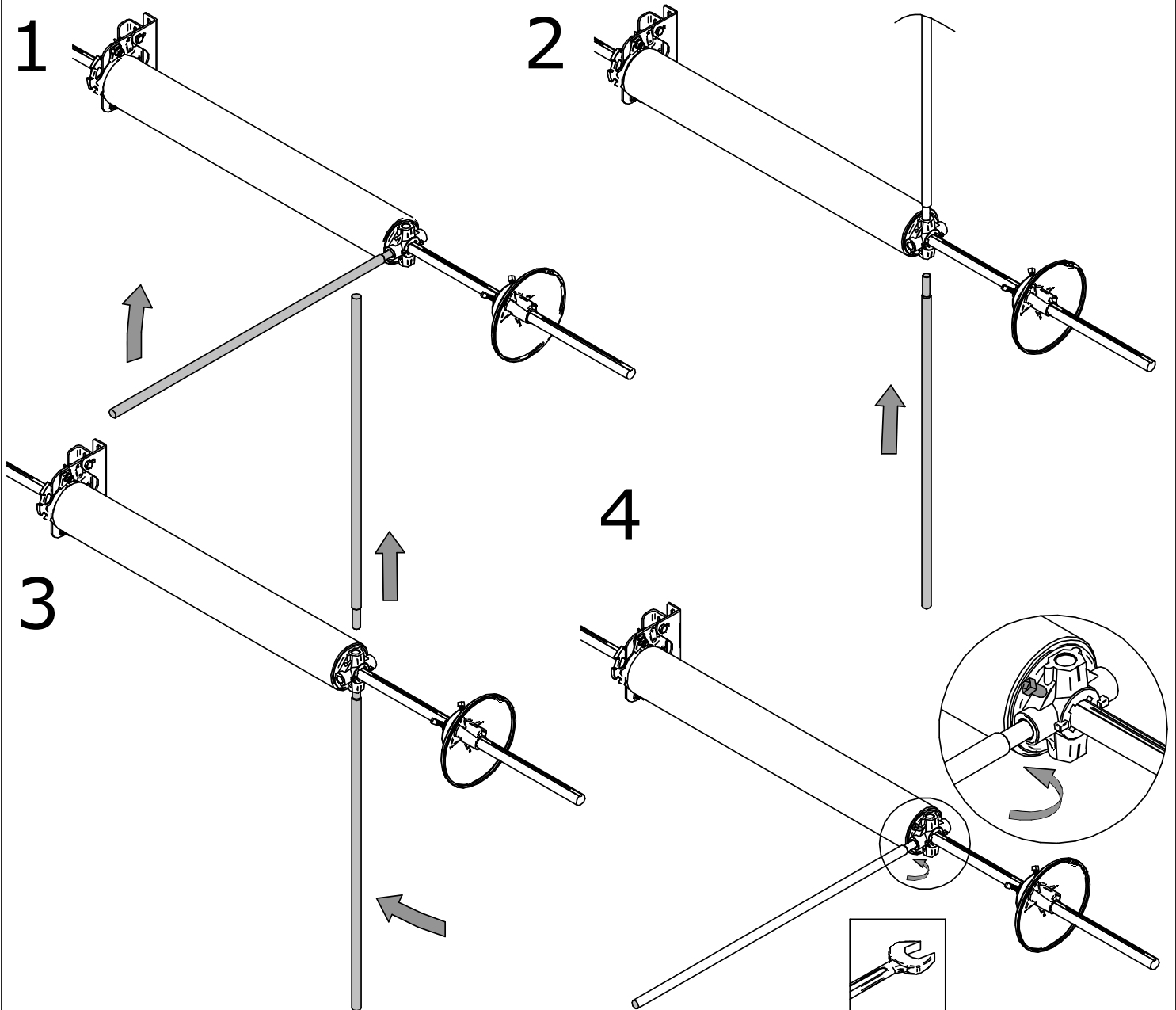

SE: Korrekt fästning/låsning av fjäderände
EN: Correct fastening of winding plug
DE: Richtige montage Feder spannkopf
FR: Fixation correcte du mandrin de tension

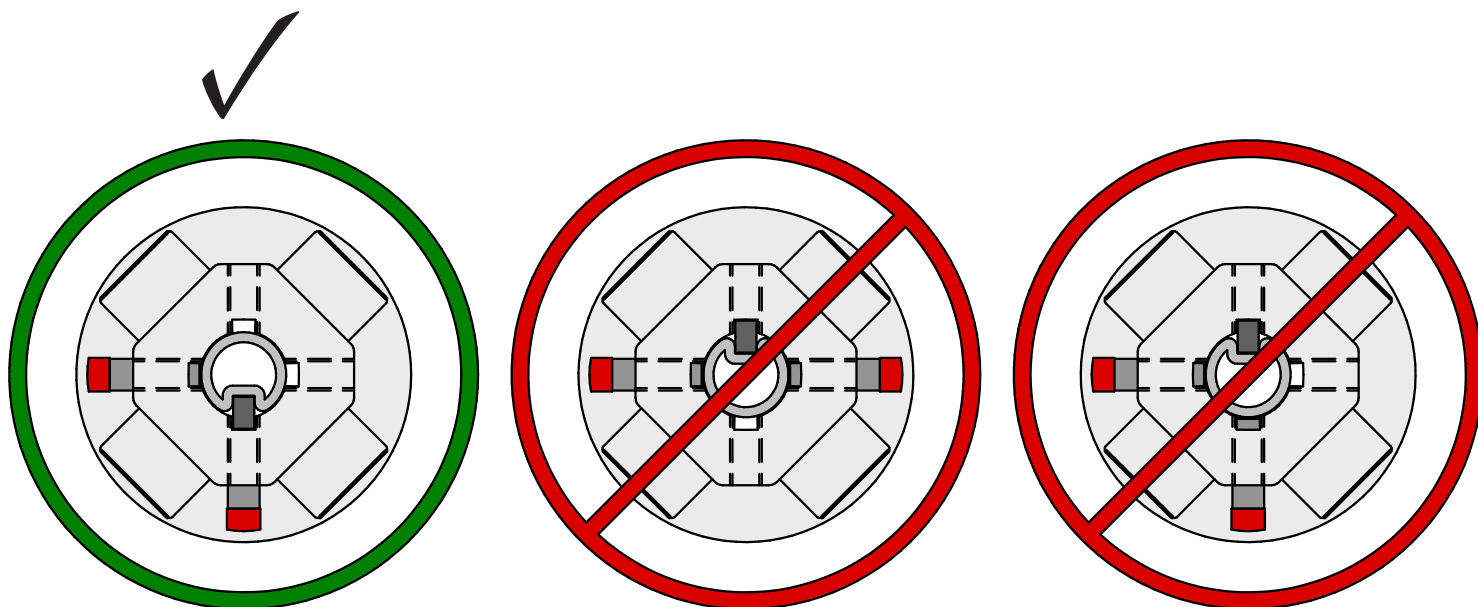

SE: Korrekt fästning/låsning av fjäderände DUPLEX
EN: Correct fastening of DUPLEX winding plug
DE: Richtige montage DUPLEX Feder spannkopf
FR: Fixation correcte du mandrin de tension DUPLEX

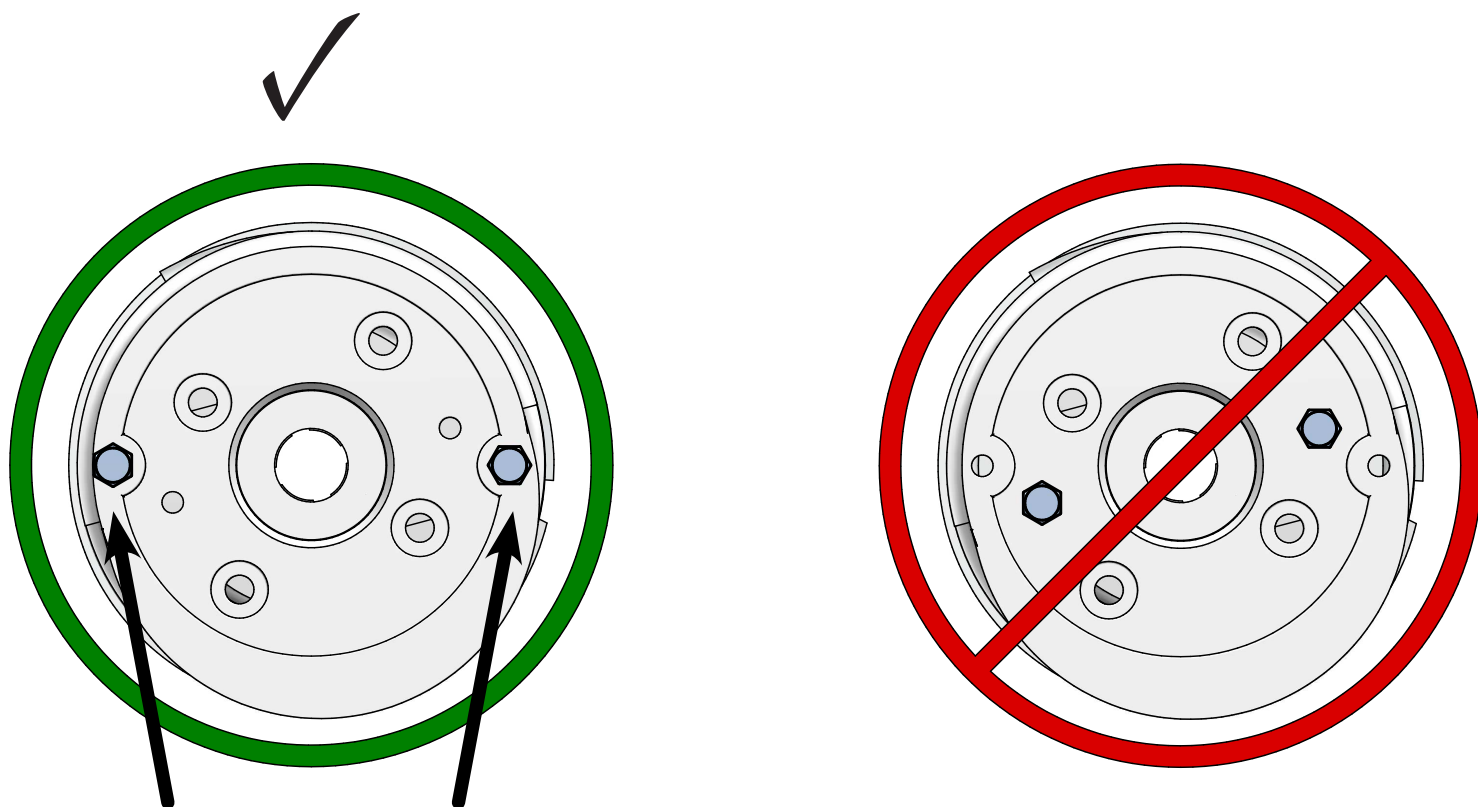

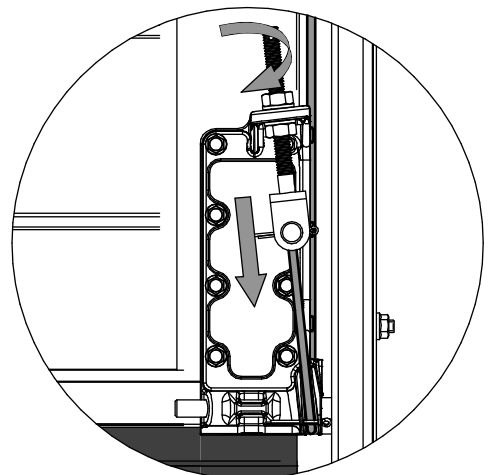
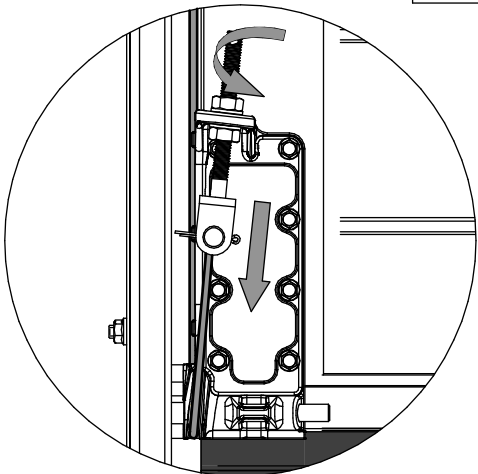
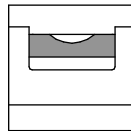
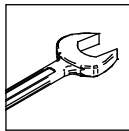
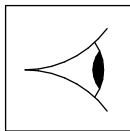
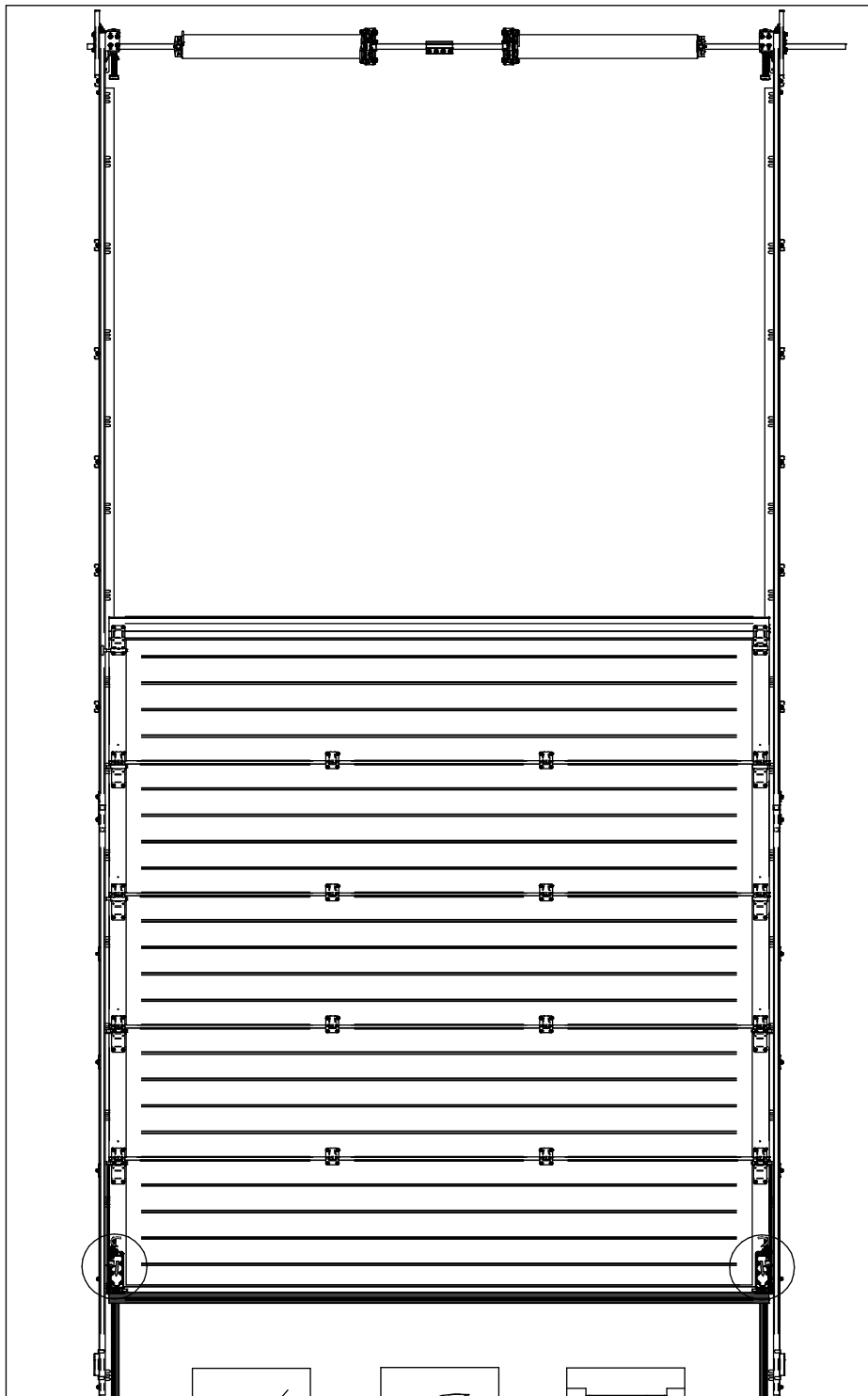

Alternativ

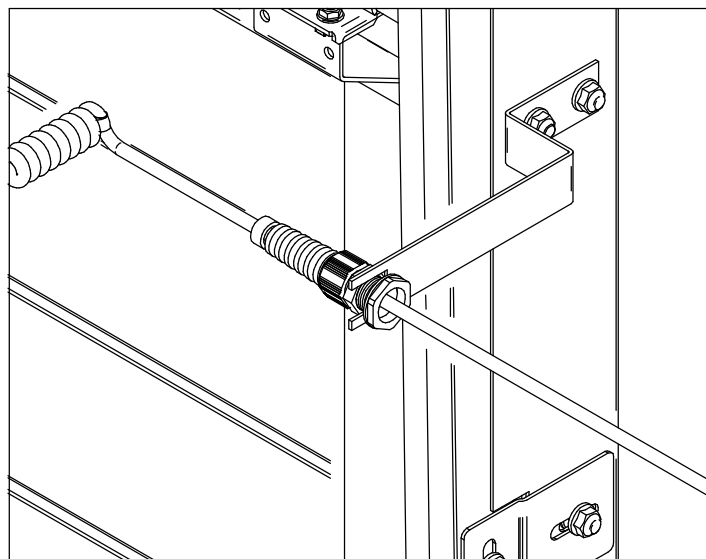
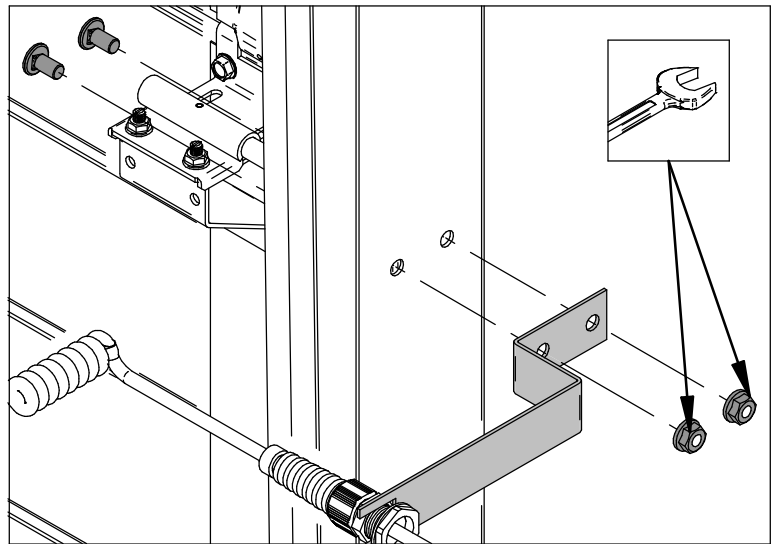
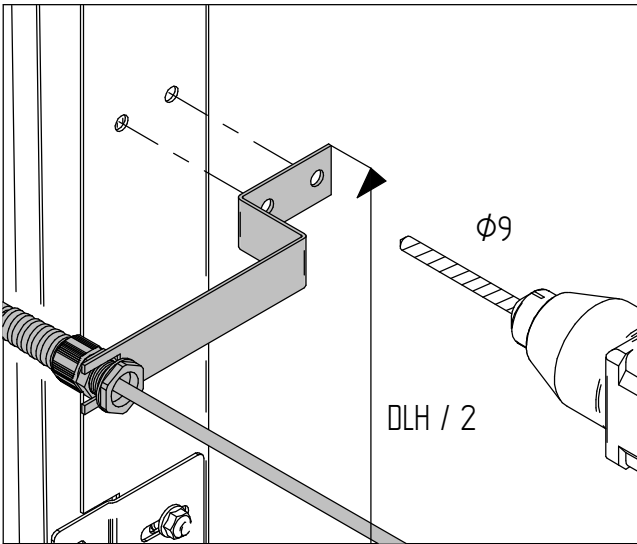
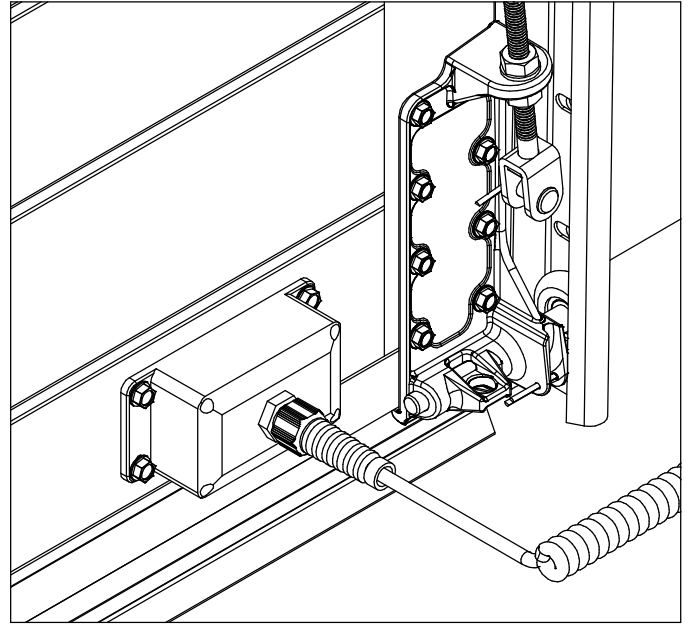
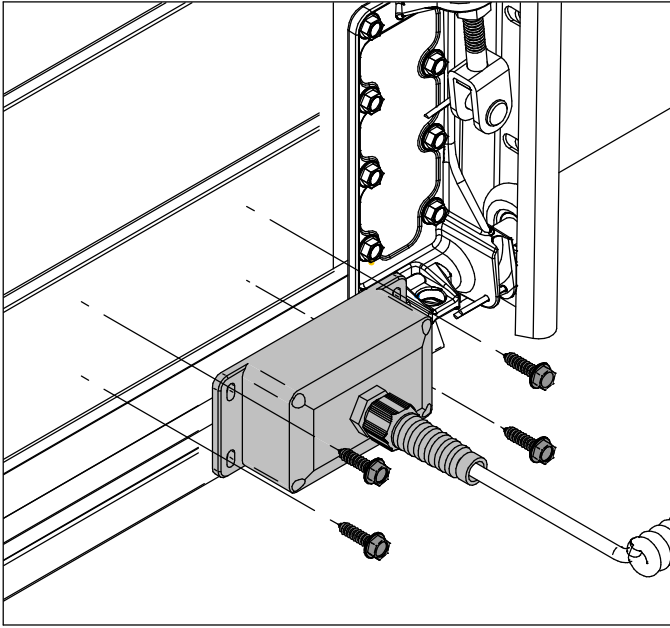

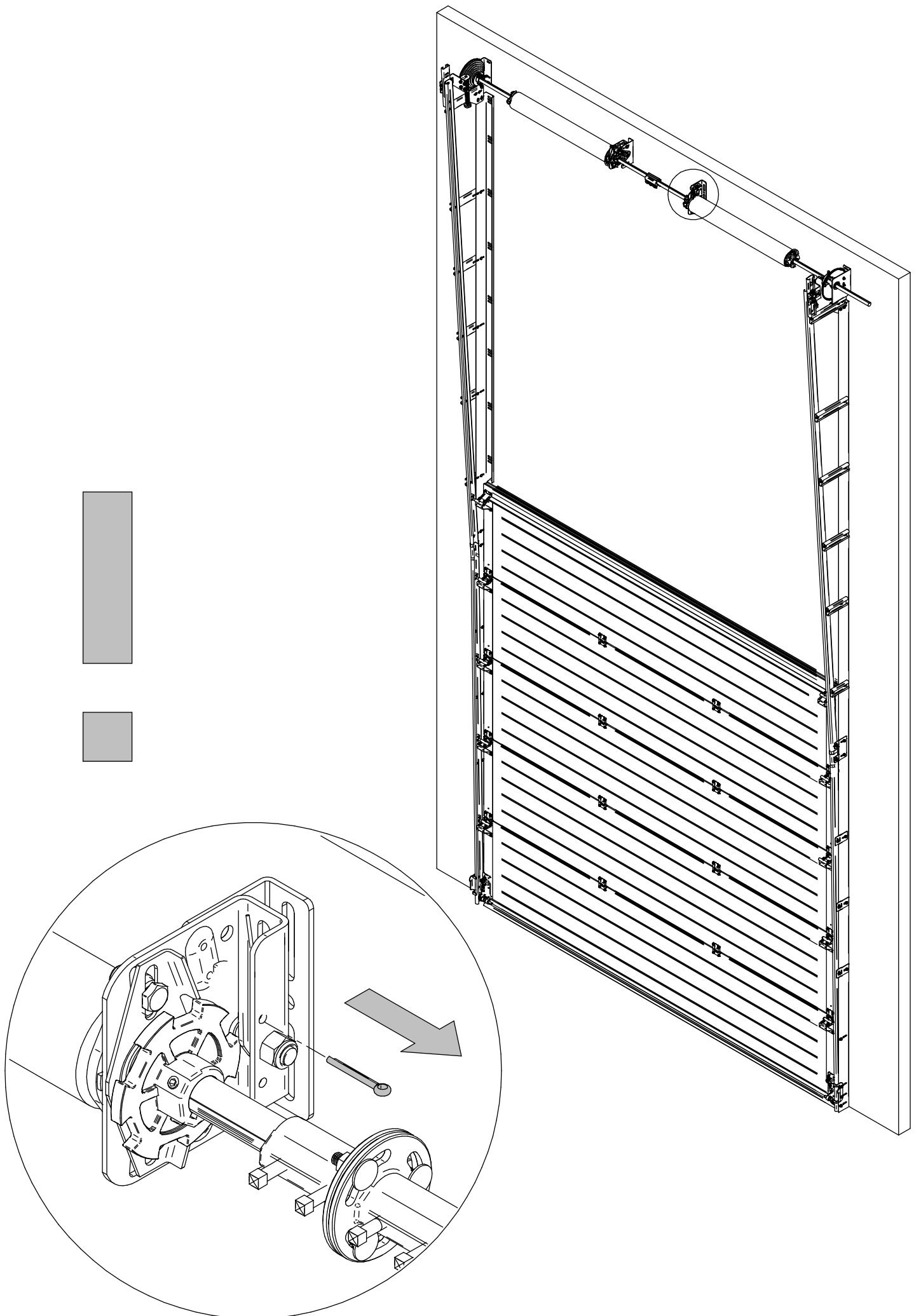

Alternativ

Förstärkningsplåtar extra tunga portar

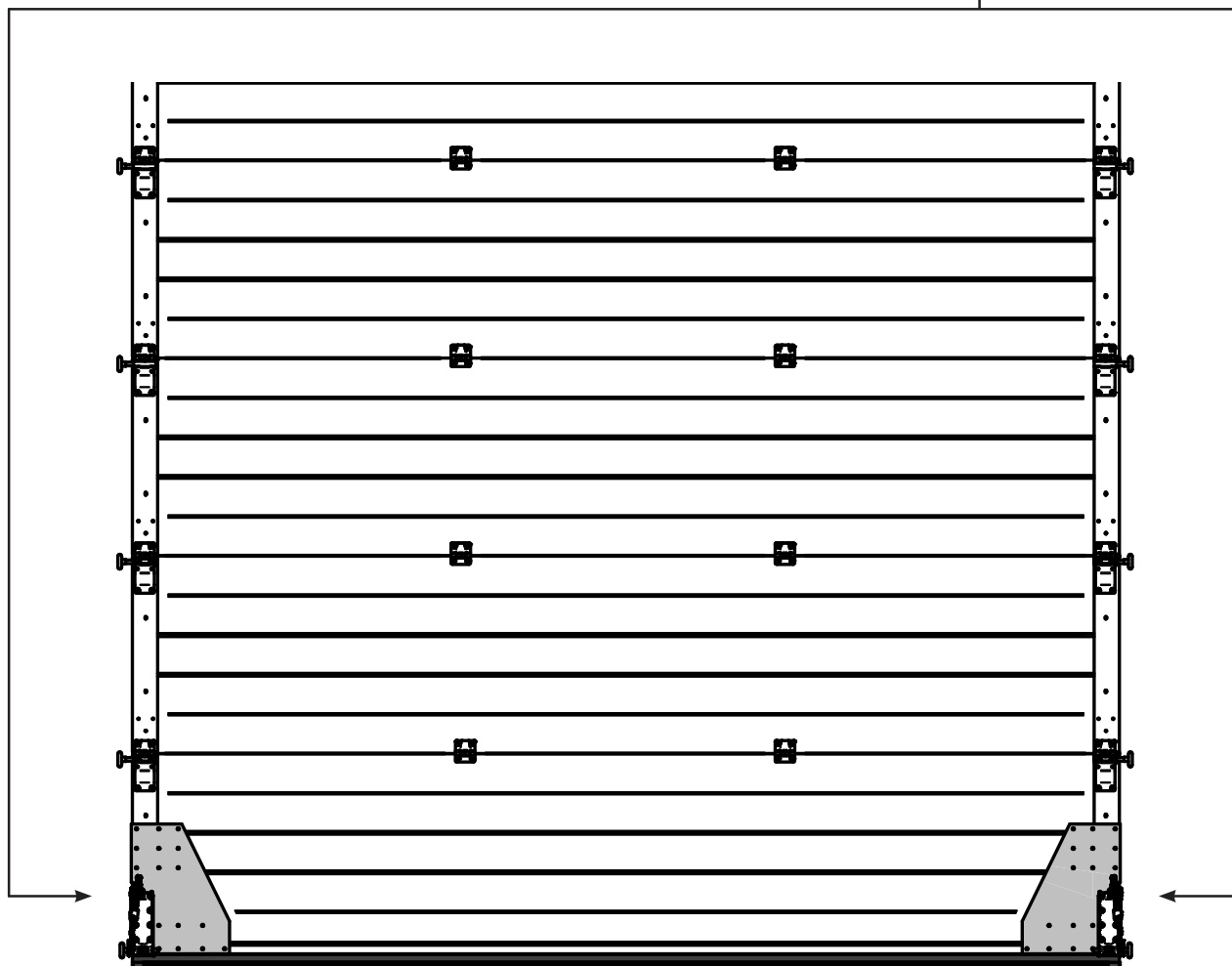
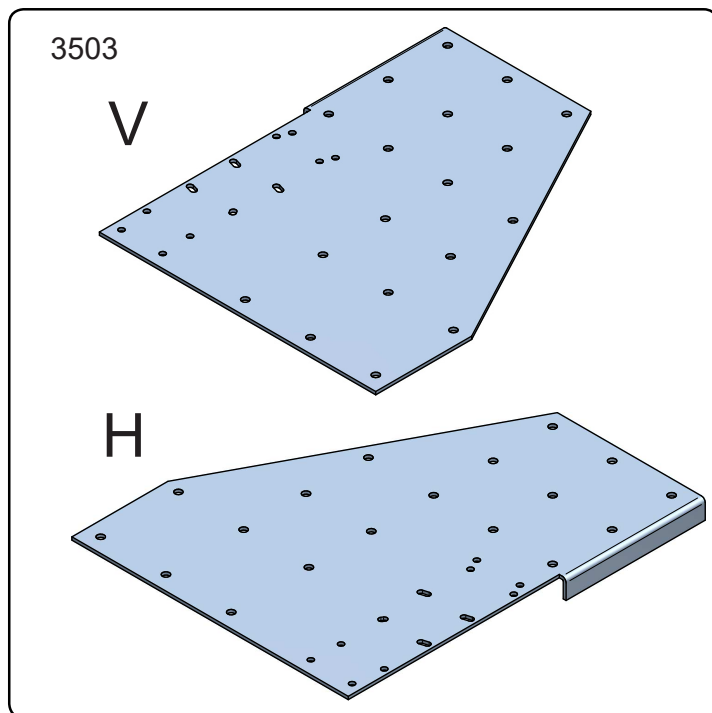
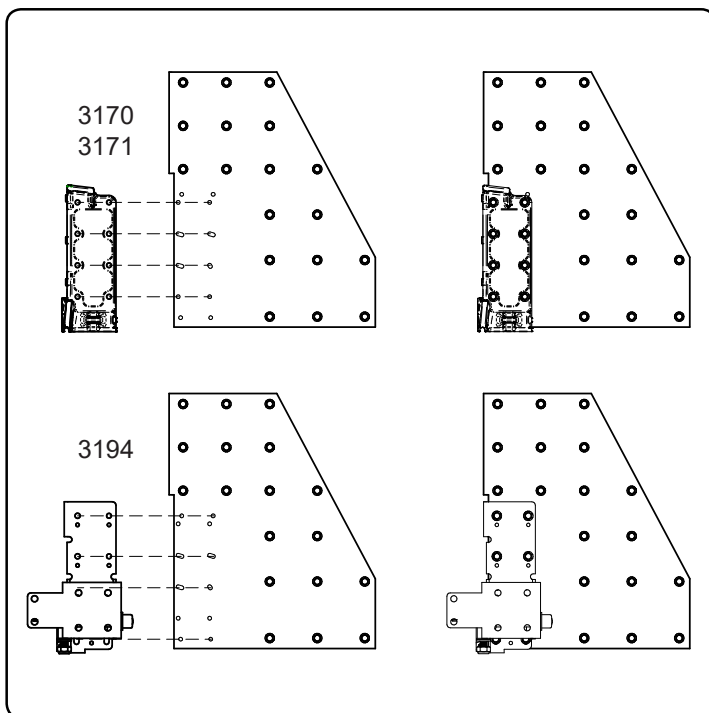

Alternativ

3639

3812

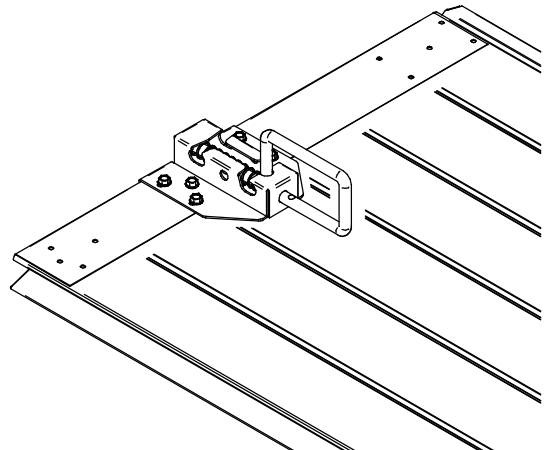
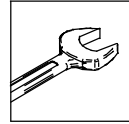
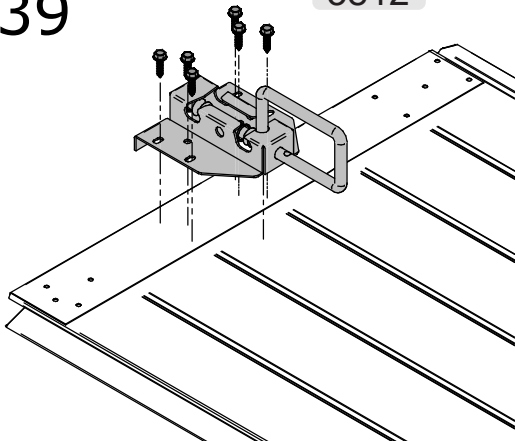

3640

3812

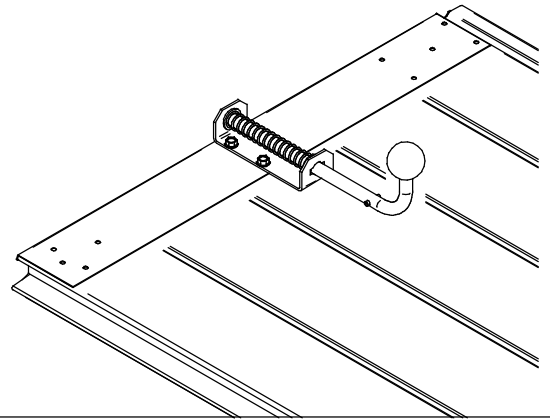
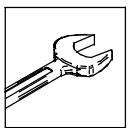
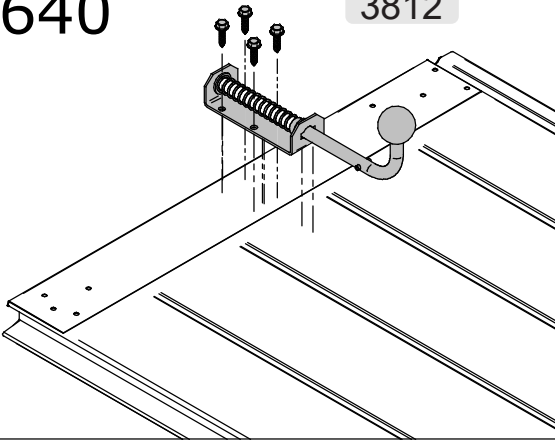

3850

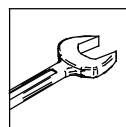
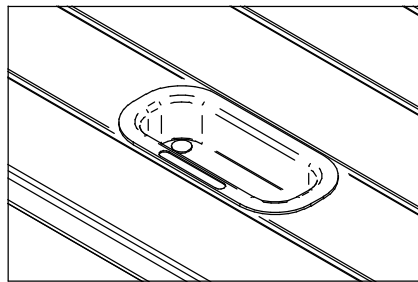
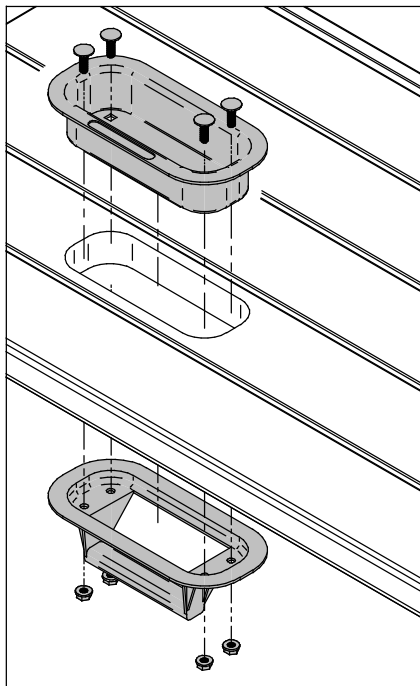

4x

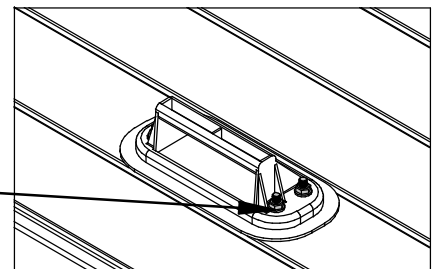

Alternativ, vaderslackbrytare

Delar

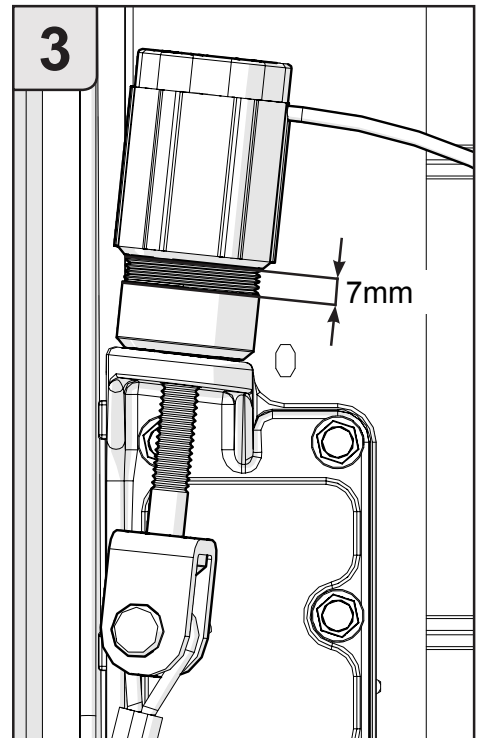
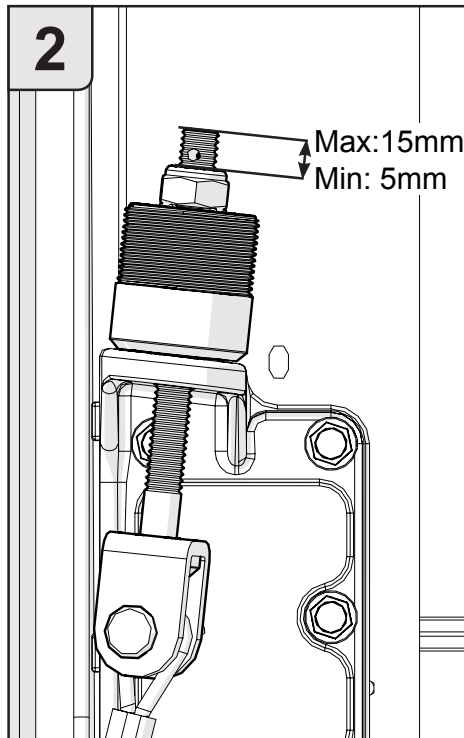
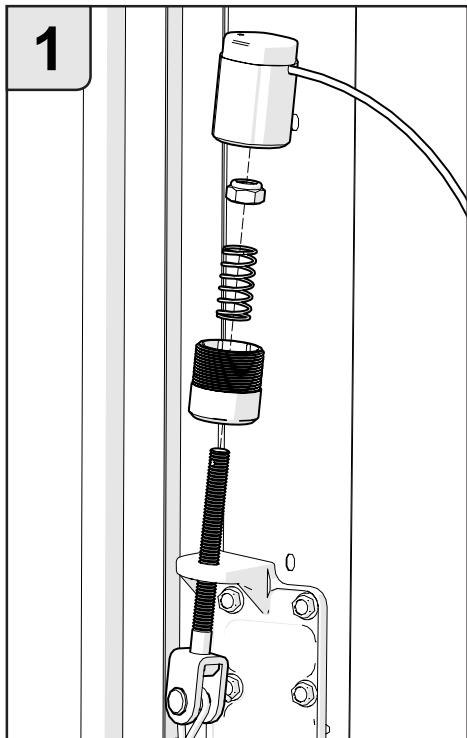
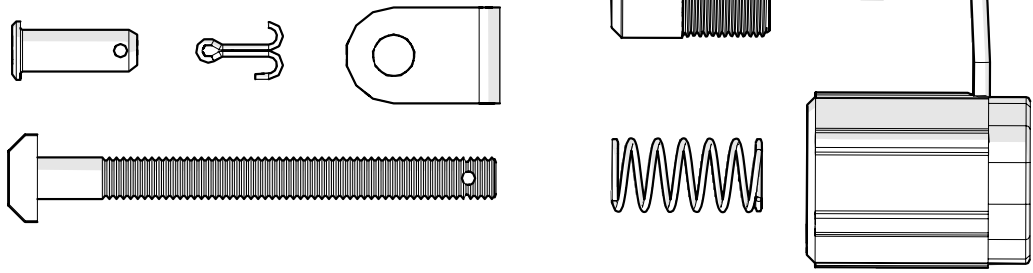

Kontroll

NC-brytare

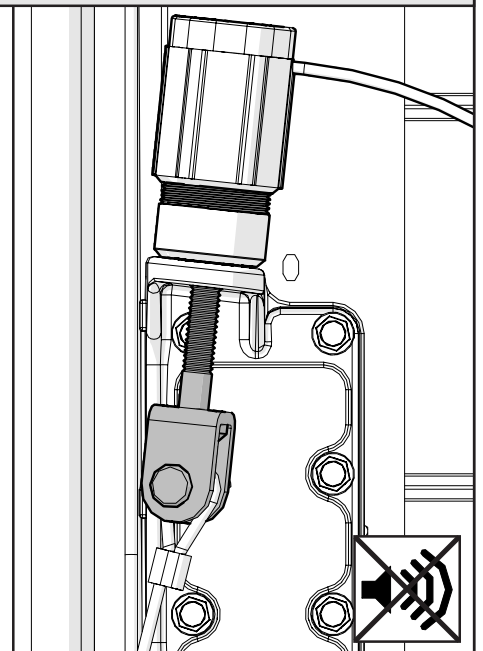
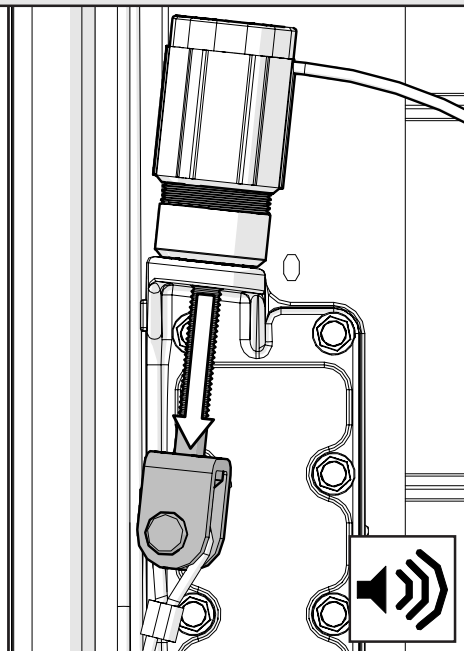
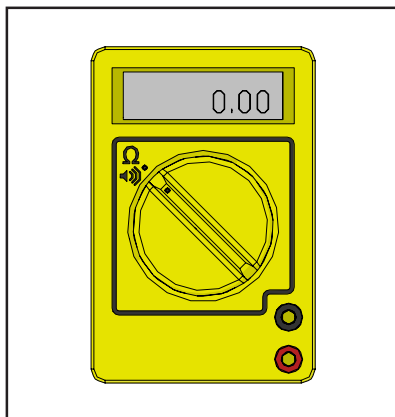

Alternativ

5363r2

SE: Monteringsanvisning Ljusridå NS/HS/VS

EN: Assembly manual Light curtain NL/HL/VL

DE: Montageanleitung Lichtgitter NS/HS/VS

FR: Manuel de montage Barrières immatérielles de sécurité LN/LH/LV

